

GLYCOL PUMPS

G

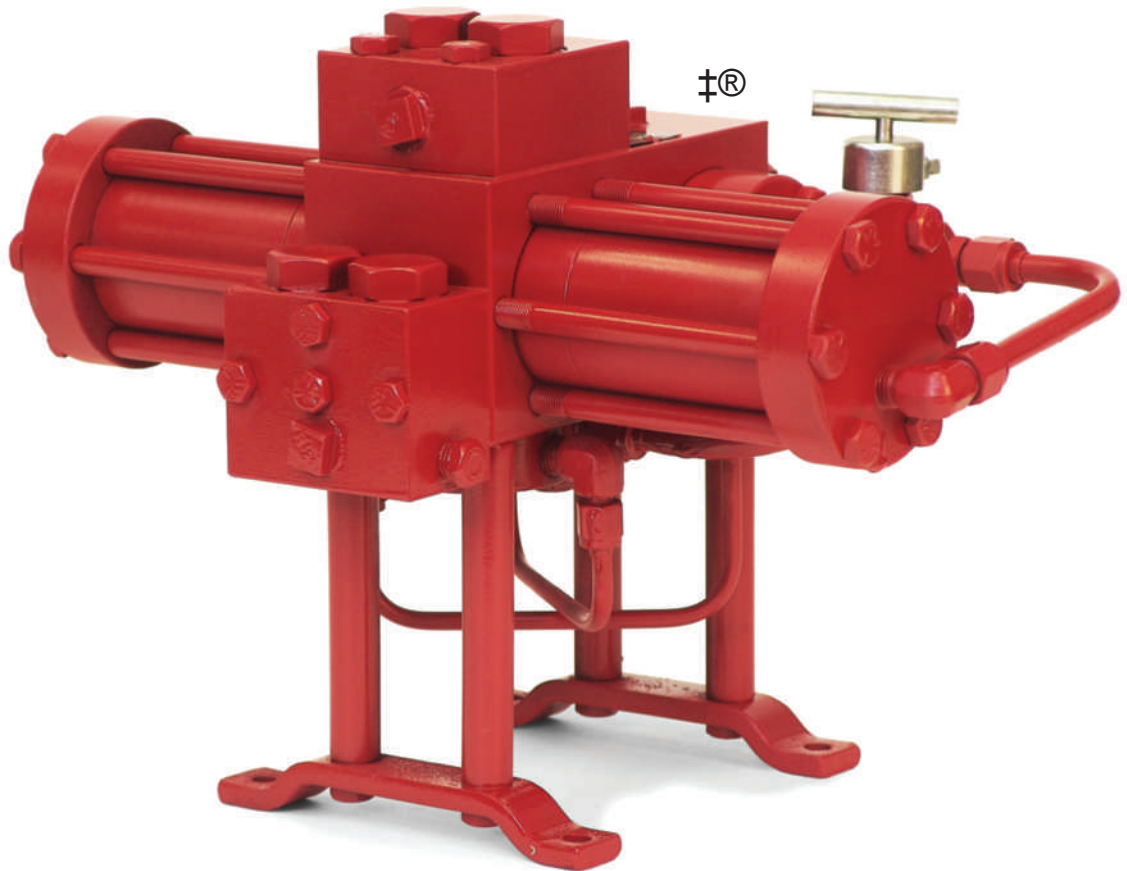

KIMRAY
INC.®

‡ Configuration of Glycol pump is a trademark of Kimray, Inc.

NOTE: We reserve the right to modify or change, without prior notice, any statement or information contained herein.
© Copyright 2020, Kimray, Inc.

ENERGY EXCHANGE GLYCOL PUMPS:	10:10.1 - 10:10.10
APPLICATIONS: Circulating pump for gas glycol dehydrators	
Circulating pump for gas amine desulphurizers	
OPERATING PRESSURE RANGES: 300 psig to 2000 psig	
40 Gallons Per Hour Pump:	10:10.3
90 Gallons Per Hour Pump:	10:10.4
210 Gallons Per Hour Pump:	10:10.5
450 Gallons Per Hour Pump:	10:10.6
20 Gallons Per Hour Pump:	10:10.7
50 Gallons Per Hour Pump:	10:10.8
100 Gallons Per Hour Pump:	10:10.9
200 Gallons Per Hour Pump:	10:10.10
ENERGY EXCHANGE GLYCOL PUMP NEEDLE VALVES:	10:10.11
ENERGY EXCHANGE GLYCOL PUMP SPLIT DISCHARGE BLOCK:	10:10.12
ENERGY EXCHANGE GLYCOL PUMP SMALL CYLINDER CONVERSION:	10:10.13
ENERGY EXCHANGE GLYCOL PUMP CAPACITIES & DIMENSIONS:	10:10.14
ENERGY EXCHANGE GLYCOL PUMP CONSUMPTION / CIRCULATION CHARTS:	10:10.15
ENERGY EXCHANGE GLYCOL PUMP OPERATING PARAMETERS:	10:10.16 - 10:10.19
ENERGY EXCHANGE GLYCOL PUMP SEALS:	10:10.22
ENERGY EXCHANGE GLYCOL PUMP MATERIALS OF CONSTRUCTION:	10:10.21
ELECTRIC GLYCOL PUMPS:	10:20.1 - 10:20.14
APPLICATIONS: Circulating pump for gas glycol dehydrators	
Circulating pump for gas amine desulphurizers	
OPERATING PRESSURE RANGES: 0 psig to 1500 psig	
8.3 Gallons Per Minute Pump:	10:20.1 - 10:20.7
2.2 Gallons Per Minute Pump:	10:20.9 - 10:20.14
ELECTRIC GLYCOL PUMP INSTALLATION:	10:25.1 - 10:25.2
ELECTRIC GLYCOL PUMP MAINTENANCE:	10:25.3
ELECTRIC GLYCOL PUMP TROUBLESHOOTING:	10:25.4
ELECTRIC GLYCOL PUMP ACCESSORIES:	10:25.5
CIRCULATION RATE	10:I
SYSTEM OPERATING PARAMETERS	10:II
DIMENSIONS	10:III
SEALS	10:IV
MATERIAL SPECIFICATIONS	10:V
ACTUATOR CRACK TO FULL OPEN	10:VI

GLYCOL PUMPS



CODE BUILDER G SERIES

Series:

G = Glycol Pump

Model:

PV = Energy Exchange

Capacity

	Flow Rate (gph)	Operating Pressure (psi)
040	12-40	300 - 2000
090	27-90	
210	66-210	400 - 2000
450	166-450	
020	8-20	100 - 500
050	12-50	
100	22-100	
200	60-200	

Service Type:

S = Standard

G **PV** **040** **S**

Options: Additional cost and lead times will apply
If multiple options required input in sequential order
Leave blank if no options required

A = AFLAS Elastomers
V = FKM Elastomers
X = Export

Not all selections available on all products listed.
See product pages 10:10.1 - 10:10.10 for available options

Series:

G = Glycol Pump

Model:

EV = Electric

Capacity

	Flow Rate (gph)	Operating Pressure (psi)
120	6-130	1200 max
500	90-500	1500 max

Service Type:

S = Standard

G **EV** **500** **S**

Options: Additional cost and lead times will apply
If multiple options required input in sequential order
Leave blank if no options required

Motor / Skid Packages				
M01 = 2HP	115/230V	1PH	1800 RPM	120 Motors
M02 = 2HP	230/460V	3PH	1800 RPM	
M03 = 3HP	115/230V	1PH	1800 RPM	
M04 = 3HP	230/460V	3PH	1800 RPM	
M05 = 3HP	115/230V	1PH	1200 RPM	500 Motors
M06 = 3HP	230/460V	3PH	1200 RPM	
* M07 = 3HP	460V	3PH	1200 RPM	
M08 = 5HP	230V	1PH	1200 RPM	
M09 = 5HP	230/460V	3PH	1200 RPM	
* M10 = 5HP	460V	3PH	1200 RPM	
M11 = 7.5HP	230/460V	3PH	1200 RPM	
* M12 = 7.5HP	460V	3PH	1200 RPM	
M13 = 10HP	230/460V	3PH	1200 RPM	
* M14 = 10HP	460V	3PH	1200 RPM	
X = Export				

Meets Specification IEEE Std. 841

Not all selections available on all products listed.
See product pages 10:20.1 - 10:20.14 for available options

NOTES:



Kimray is an ISO 9001- certified manufacturer.

APPLICATIONS:

- Circulating pump for gas glycol dehydrators
- Circulating pump for gas amine desulphurizers

FEATURES:







- Eliminates absorber liquid level controls
- No auxiliary power supply required
- Low gas consumption
- Completely sealed system prevents loss of glycol
- No springs or toggles, only two moving assemblies
- Hydraulic "cushioned" check valves with removable seats of hardened stainless steel

CERTIFICATIONS:

Kimray is an ISO 9001- certified manufacturer.

INTRODUCTION:

The Glycol Energy Exchange Pump, "Pressure Volume" or "PV-Series" Pump was developed in 1957. The initial consideration was a pump that would utilize the energy of the wet glycol at absorber pressure as a source of power. Within the confines of a system, energy can neither be created nor destroyed. Energy can, however, be stored, transferred, or changed from one form to another. The PV Series Pump transfers the energy available from the wet glycol, at absorber pressure, to an "equivalent" volume of dry glycol at reboiler pressure. In order to circulate the glycol, additional energy is needed to overcome friction losses within the pump and connecting piping. This additional energy is supplied by gas at absorber pressure.

-  "D" Slide
-  Pump Piston Assembly
-  Wet Glycol from Absorber (High Pressure)
-  Wet Glycol from Reboiler (Low Pressure)
-  Dry Glycol from Absorber (High Pressure)
-  Dry Glycol from Reboiler (Low Pressure)

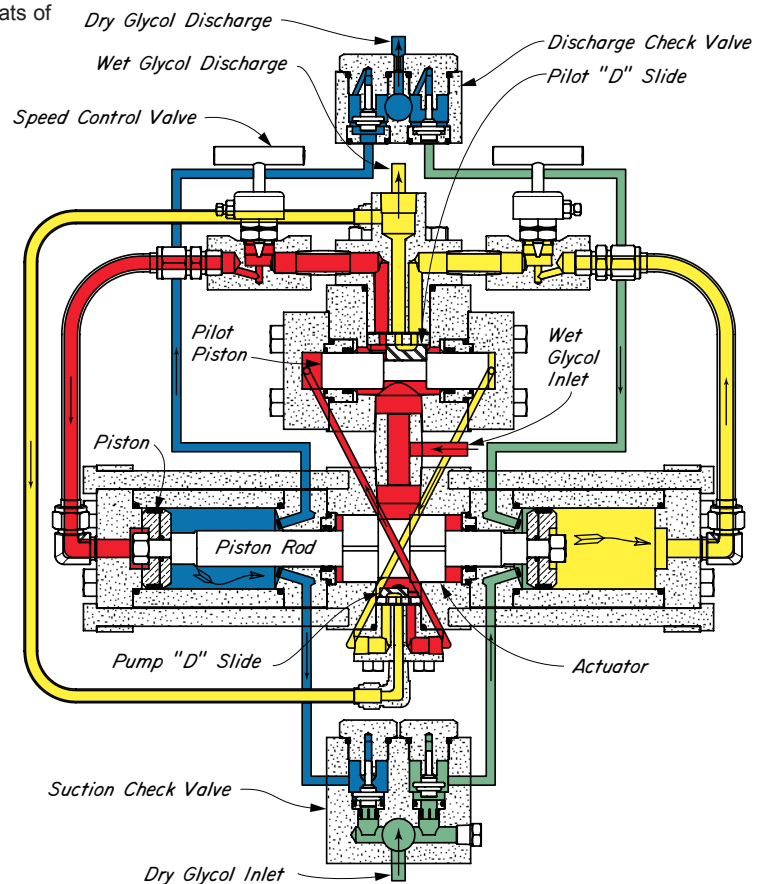

Standard Configuration Code †	Order Code	Gallons per hour Minimum	Gallons per hour Maximum ††	Operating Pressure Minimum	Operating Pressure Maximum
GPV040S	GABHSN	12	40	300	2000
GPV090S	GAFHSN	27	90	400	
GPV210S	GAHHSN	66	210		
GPV450S	GAJHSN	166	450	100	500
GPV020S	GACHSN	8	20		
GPV050S	GAGHSN	12	50		
GPV100S	GAIHSN	22	100		
GPV200S	GAKHSN	60	200		

NOTES:

For standard & optional seals, metals, material specifications & dimensions see technical data on pages 10:1 - 10:VI

† For code builder see page 10:00.2

†† Maximum output is affected by system pressure drops. See system operation parameter for maximum output curves.

ENERGY EXCHANGE MODEL PV

PRINCIPLE OF OPERATION:

Actions of each of the two basic parts of the pump are completely dependent upon the other. The pilot D-slide actuated by the Pilot Piston alternately feeds and exhausts absorber pressure to the power cylinders at opposite ends of the Piston-Rod Assembly. Likewise, the Pump D-slide actuated by the Piston-Rod Assembly alternately feeds and exhausts absorber pressure to opposite ends of the Pilot Piston.

The force to circulate glycol within the dehydration system is supplied by absorber pressure acting on the area of the Piston Rod at its O-ring seals. The area of the Piston Rod is approximately 20 percent of that of the Piston. Neglecting pump friction and line losses, the resultant force is sufficient to produce a theoretical discharge pressure 25 percent greater than absorber pressure. The theoretical discharge pressure, for example, at 1500 psig absorber pressure would be 1875 psig. This theoretical "over-pressure" would develop against a blocked discharge line but is not sufficient to cause damage or create a hazard.

Approximately 25 to 30 psig pressure is required to overcome pump friction leaving the additional "over pressure" for line losses and circulation. It is recommended that these losses be held to approximately 10 percent of the absorber pressure or as noted in catalog.

Two Speed Control Valves are provided to regulate the flow of wet glycol and gas to and from the power cylinders. Reversing the direction of flow through the Speed Control Valves provides a flushing action which cleans the valve orifices.

If the wet glycol returning to the pump from the absorber were to completely fill the cylinder, no additional gas would be needed. However, the wet glycol will only occupy approximately 65 percent of the total volume of the cylinder and connecting tubing leaving 35 percent to be filled by gas from the absorber. This gas volume amounts to 1.7S.C.F. per gallon of dry glycol at 300 psig absorber pressure and 8.3S.C.F. at 1500 psig and may be considered as continuing power cost for pump operation. This gas can be utilized in the regeneration process of the dehydrator for "rolling" and or "stripping" purposes. It may also be recovered in a low pressure glycol gas separator and used to fire the reboiler pressure glycol gas separator and used to fire the reboiler.

By supplying some absorber gas to the cylinders, the wet glycol level is maintained at the wet glycol outlet connection on the absorber and eliminates the need of a liquid level controller and its attendant problems. Excess liquids such as hydrocarbons are removed from the absorber at approximately 55 percent of the pump rate, reducing the hazard of dumping a large volume of hydrocarbons into the reboiler as would be the case with a liquid level controller.

HEAT EXCHANGERS:

Sufficient heat exchange is necessary to reduce dry glycol suction temperature to at least 200°F, preferably to 150°F.

SYSTEM PRESSURE DROPS:

The Kimray Glycol Pumps are designed to operate by using the energy from the wet glycol and some additional energy in the form of gas at absorber pressure. Excessive pressure drops in the lines connecting the pump to the system can cause the pump to run erratically or stall. The following conditions should be designed into the system to assure proper pump performance:

DRY GLYCOL SUCTION LINE: Size the suction line, low pressure filter and heat exchanger such that the pump will have a positive pressure at the suction inlet when running at the maximum rated speed. This line may need to be larger than the pipe fitting on the suction check valve block. (See pipe connection sizes on page 10.28.)

WET GLYCOL POWER LINE: Recommended line size is the same as the size of the pipe connection for the given pump. (Page 10.28) The pressure drop across the high pressure filter is a factor in considering the total system pressure drop.

DRY GLYCOL DISCHARGE LINE: Recommended line size is the same as the size of the pipe connection for the given pump

and the absorber should be full opening to the recommended line size.

WET GLYCOL DISCHARGE LINE: Recommended line size is the same as the size of the pipe connection for the given pump. If a glycol gas separator is used, the pressure maintained on the separator must be considered in the total system pressure drop. Also, heat exchanger coils in accumulator tanks also add to this pressure drop.

ISOLATING VALVES: All plug, gate, or blocking valves should be full opening to the recommended line size of the given pump.

If a positive feed is supplied to the pump at the dry suction inlet, the total system pressure drop will be the sum of the following pressure drops:

1. The pressure drop between the absorber and the pump in the wet glycol line.
2. The pressure drop between the pump and the absorber in the dry glycol discharge, line including any pressure required to open and establish full flow in any check valves.
3. The pressure drop between the pump and the reboiler (at atmospheric pressure) in the wet glycol discharge line. This includes the liquid head to the reboiler, heat exchanger coil, and/or the pressure maintained on a glycol separator.

The sum of these pressure drops gives the total "system pressure drop". Exceeding the total allowable system pressure drop will cause the pump to run erratically or to stall.

To determine if a problem exists in an operating dehydration system, slowly open the speed control valves on the pump until it runs at the maximum recommended pump speed. If the Pump cavitates before reaching the maximum pump speed, the suction line is restricted. If the pump will not run at the maximum rated speed, then there are probably restrictions in one or more of the other three connecting lines.

FILTERS:

Filters should be used on every dehydrator for protection of both the pump and reboiler. Many pumps are severely damaged in the first minutes or days of operation from flow line and vessel debris. Reboilers have been known to be filled with sand which had to first pass through the pump.

Filters should give protection from 25 to 150 micron particle sizes depending on the specific condition. The disc type, micron type, and sock type have all proven very satisfactory if they are properly maintained. Some metal filters are equipped with a cleaning device which should be operated daily or at least every few days as experience may dictate. Sock filters must be replaced at regular intervals.

A spring loaded by-pass on the filter is not recommended. It is better for the pump to stall due to lack of power than be exposed to dirt and grit from an open by-pass. Always install a high pressure filter between the absorber and the pump. A filter on the wet glycol discharge of the pump will protect the reboiler but does nothing for the pump. A low pressure filter on the pump suction line protects against metallic particles from a new reboiler and its connecting piping. Filters will also keep the glycol free of heavy tars and residue from evaporated hydrocarbons and resinous compounds caused by polymerization of the glycol. Sock type filters are probably best for this type of filtration but should be changed rather frequently.

In addition to using filters it is often necessary to take a chemical analysis of the glycol, not only for pump protection but for better dehydration. Organic acids in glycol are produced from oxidation, thermal decomposition, and acid gases from the gas stream. These acids cause corrosion in the system, and dissolve the plating on pump parts in a short time. Glycol acidity should be maintained between a pH of 7 to 9. Alkaline amines are usually recommended to control the pH value because they will neutralize any acid gases present and are easily regenerated.

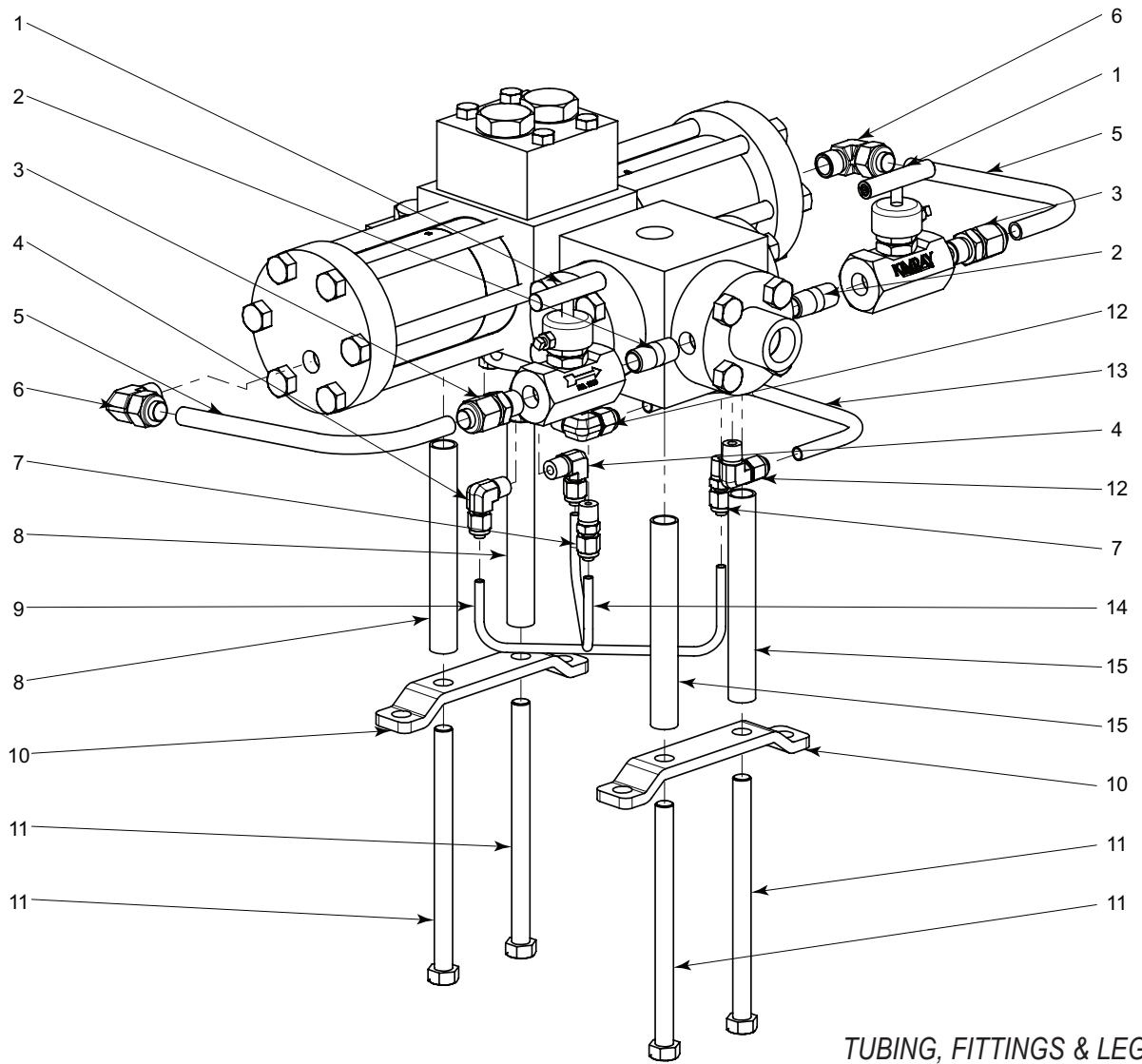

TUBING, FITTINGS & LEGS

ITEM	QTY.	DESCRIPTION	PART NUMBER							
			GPV020S	GPV040S	GPV050S	GPV090S	GPV100S	GPV200S	GPV210S	GPV450S
1	2	Needle Valve	1911	1957	1957	1956	1956	1955	1955	1954
2	2	Nipple	648	648	7287	271	7288	7289	858	1186
3	2	Connector	876	876	876	878	878	880	880	1188
4	2	Ell	875	875	875	875	877	879	877	879
5	2	Tubing	868	868	869	869	870	1187	870	1187
6	2	Ell	877	877	877	879	879	7574	881	1189
	2	Bushing	----	----	234	----	892	----	----	----
7	2	Connector	874	874	874	874	876	878	876	878
8	2	Spacer	759	759	760	760	761	1176	761	1176
9	1	Tubing	958SS6L	958SS6L	959SS6L	959SS6L	891L	6421L	891L	6421L
10	1	Feet	756	756	757	757	758	1175	758	1175
11	2	Bolt	782	782	783	783	783	1142	783	1142
12	2	Ell	877	877	877	877	879	881	879	881
13	1	Tubing	960	960	961	961	864	6420	864	6420
14	1	Tubing	958SS6S	958SS6S	959SS6S	959SS6S	891S	6421S	891S	6421S
15	2	Spacer	759	759	760	760	760	1176	760	1176
Repair Kits			RJD1-HSN	RJB1-HSN	RJH1-HSN	RJF1-HSN	RJK1-HSN	RJN1-HSN	RJI1-HSN	RJL1-HSN

* These parts are recommended spare parts and are stocked as repair kits.

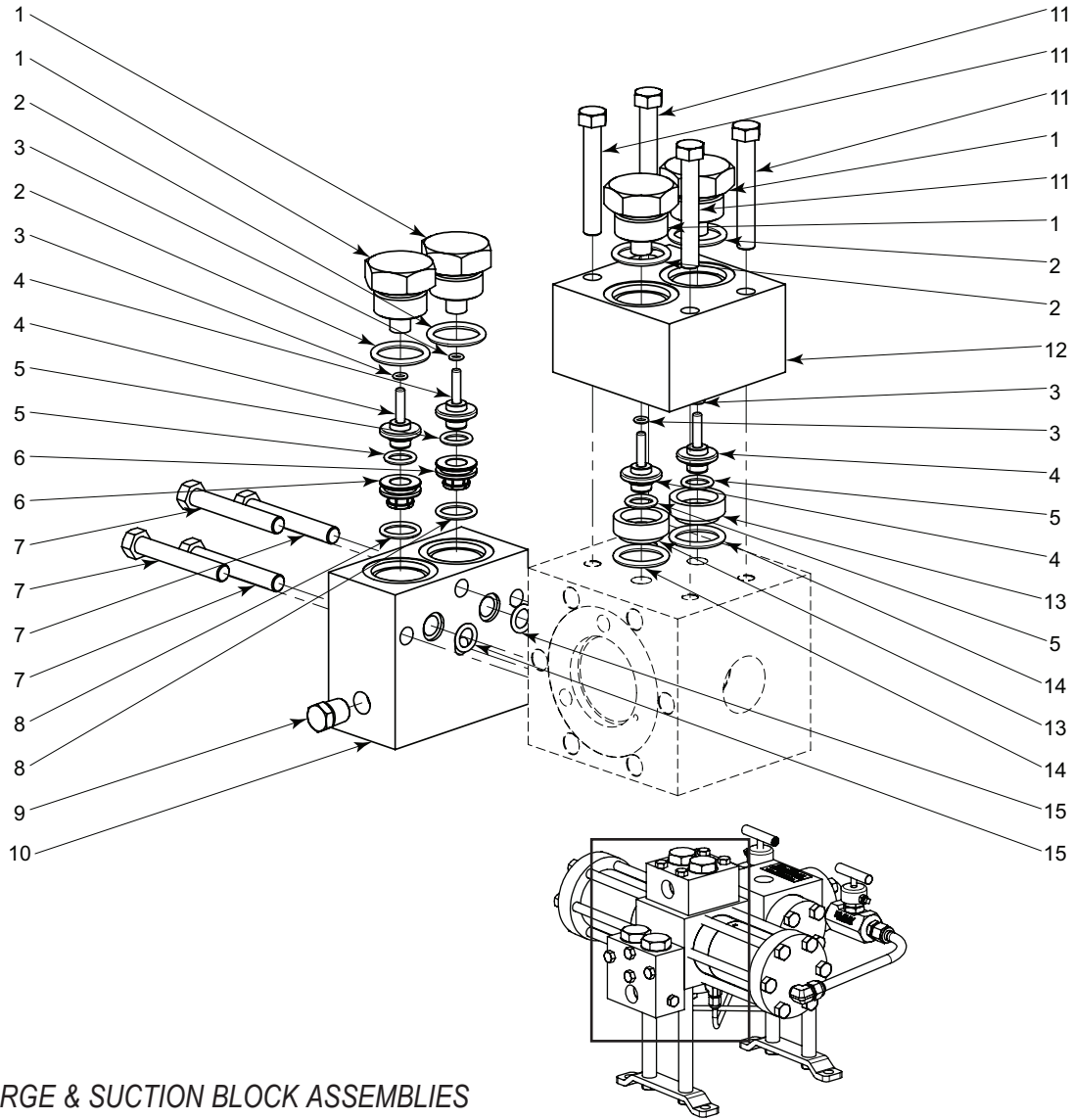

DISCHARGE & SUCTION BLOCK ASSEMBLIES

ITEM	QTY.	DESCRIPTION	PART NUMBER							
			GPV020S	GPV040S	GPV050S	GPV090S	GPV100S	GPV200S	GPV210S	GPV450S
1	4	Check Valve Cap	1308	1308	931	931	851	1162	851	1162
2	4	O-Ring	* 155HSN	155HSN	156HSN	156HSN	157HSN	801HSN	157HSN	801HSN
3	4	O-Ring	* 647HSN	647HSN	647HSN	647HSN	153HSN	265HSN	153HSN	265HSN
4	4	Check Valve Dart	1307K	1307K	853K	853K	854K	1163K	854K	1163K
5	4	O-Ring	* 855HSN	855HSN	154HSN	154HSN	924HSN	156HSN	924HSN	156HSN
6	2	Removable Seat Suction	1153K	1153K	1132K	1132K	1134K	1173K	1134K	1173K
7	(Qty)	Bolt	964 (4)	964 (4)	907 (4)	907 (4)	867(5)	1143 (7)	867(5)	1143 (7)
8	2	O-Ring	* 530HSN	530HSN	924HSN	924HSN	1107HSN	157HSN	1107HSN	157HSN
9	1	Plug	699	699	699	699	292	1192	292	1192
10	1	Suction Block	952K	952K	930K	930K	848K	1160K	848K	1160K
11	(Qty)	Bolt		965 (3)		907 (4)			861 (4)	826 (4)
12	1	Discharge Block	951	951	929	929	934	1161	934	1161
13	2	Removable Seat Discharge	1152K	1152K	1131K	1131K	1133K	1174K	1133K	1174K
14	2	O-Ring	* 491HSN	491HSN	1151HSN	1151HSN	156HSN	801HSN	156HSN	801HSN
15	2	O-Ring	* 153HSN	153HSN	530HSN	530HSN	924HSN	1182HSN	924HSN	1182HSN
Repair Kits			RJD1-HSN	RJB1-HSN	RJH1-HSN	RJF1-HSN	RJK1-HSN	RJN1-HSN	RJI1-HSN	RJL1-HSN

* These parts are recommended spare parts and are stocked as repair kits.

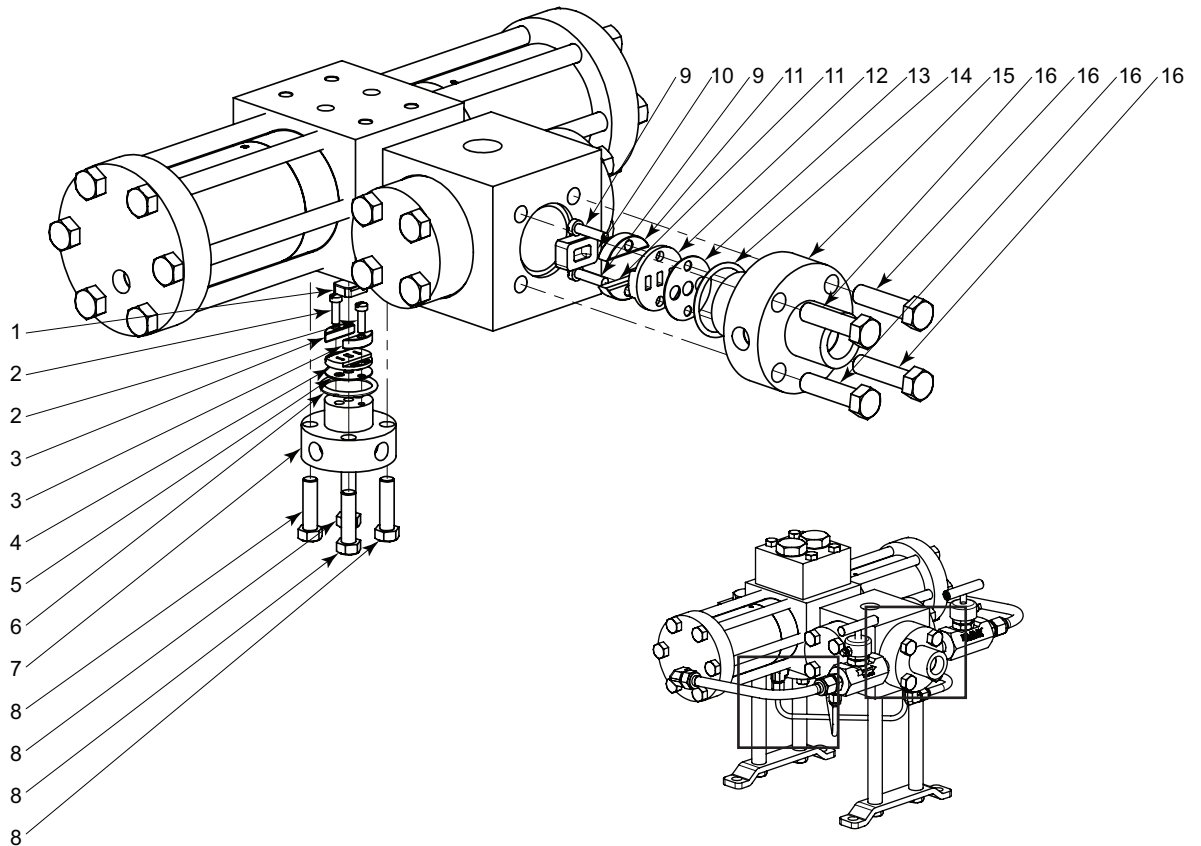

PILOT & MAIN PISTON HOUSING ASSEMBLIES

ITEM	QTY.	DESCRIPTION	PART NUMBER							
			GPV020S	GPV040S	GPV050S	GPV090S	GPV100S	GPV200S	GPV210S	GPV450S
1	1	Main Piston "D" Slide *	818	818	818	818	819	820	819	820
2	2	Screw	905	905	905	905	1612	6828	1612	6828
3	2	Main Piston "D" Slid Guide	841	841	841	841	842	843	842	843
4	1	Main Piston Port Plate	5624	5624	5624	5624	5632	5637	5632	5637
5	1	Main Port Plate Gasket *	5620	5620	5620	5620	5629	5629	5629	5629
6	1	O-Ring *	157HSN	157HSN	157HSN	157HSN	801HSN	821HSN	801HSN	821HSN
7	1	Main Piston Housing	5625	5625	5625	5625	5633	5627	5633	5627
8	4	Bolt	794	794	794	794	825	826	825	826
9	2	Screw	905	905	6883	6883	6883	1612	6883	1612
10	1	Pilot Piston "D" Slide *	818	818	819	819	820	1172	820	1172
11	2	Pilot Piston "D" Slid Guide	841	841	842	842	843	1171	843	1171
12	1	Pilot Piston Port Plate	5621	5621	5626	5626	5630	5635	5630	5635
13	1	Pilot Port Plate Gasket *	5620	5620	5623	5623	5623	5634	5623	5634
14	1	O-Ring *	157HSN	157HSN	801HSN	801HSN	802HSN	1179HSN	802HSN	1179HSN
15	1	Pilot Piston Housing	5622	5622	5628	5628	5631	5636	5631	5636
16	4	Bolt	794	794	825	825	826	826	826	826
Repair Kits			RJD1-HSN	RJB1-HSN	RJH1-HSN	RJF1-HSN	RJK1-HSN	RJN1-HSN	RJI1-HSN	RJL1-HSN
			* These parts are recommended spare parts and are stocked as repair kits.							

GLYCOL PUMPS

ENERGY EXCHANGE
MODEL PV

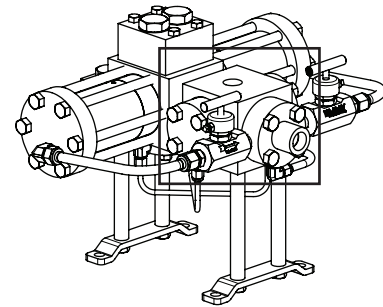
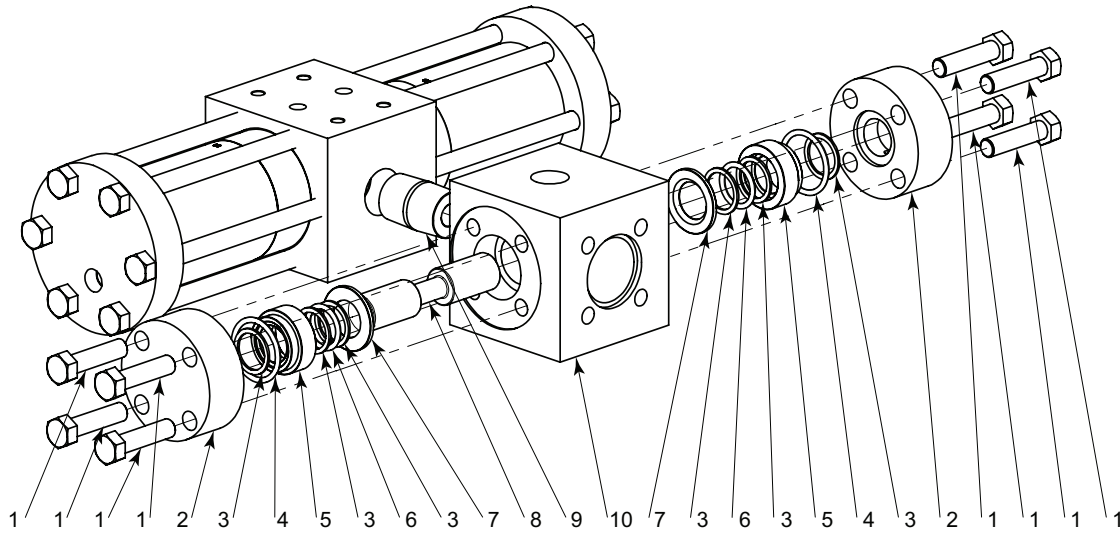

PILOT PISTON BLOCK & CAP ASSEMBLY

ITEM	QTY.	DESCRIPTION	PART NUMBER							
			GPV020S	GPV040S	GPV050S	GPV090S	GPV100S	GPV200S	GPV210S	GPV450S
1	8	Bolt	833	833	825	825	834	1144	834	1144
2	2	Pilot Piston Cap	804	804	805	805	806	1170	806	1170
3	6	Back-up *	809	809	810	810	811	1157	811	1157
4	2	O-Ring *	606HSN	606HSN	773HSN	773HSN	801HSN	1108HSN	801HSN	1108HSN
5	2	Pilot Piston Bearing	812	812	813	813	814	1168	814	1168
6	2	O-Ring *	807HSN	807HSN	156HSN	156HSN	808HSN	1180HSN	808HSN	1180HSN
7	2	Pilot Piston Seal Retainer	815	815	816	816	817	1169	817	1169
8	1	Pilot Piston	830	830	831	831	832	1167	832	1167
9	1	Nipple	----	----	935	935	935	1193	935	1193
10	1	Pilot Piston Block	----	----	923	923	933	1166	933	1166
Repair Kits			RJD1-HSN	RJB1-HSN	RJH1-HSN	RJF1-HSN	RJK1-HSN	RJN1-HSN	RJI1-HSN	RJL1-HSN
			* These parts are recommended spare parts and are stocked as repair kits.							

All Pictures shown are for illustration purpose only. Actual product may vary due to product enhancement.
‡ Configuration of Glycol Pump is a trademark of Kimray, Inc.
www.kimray.com

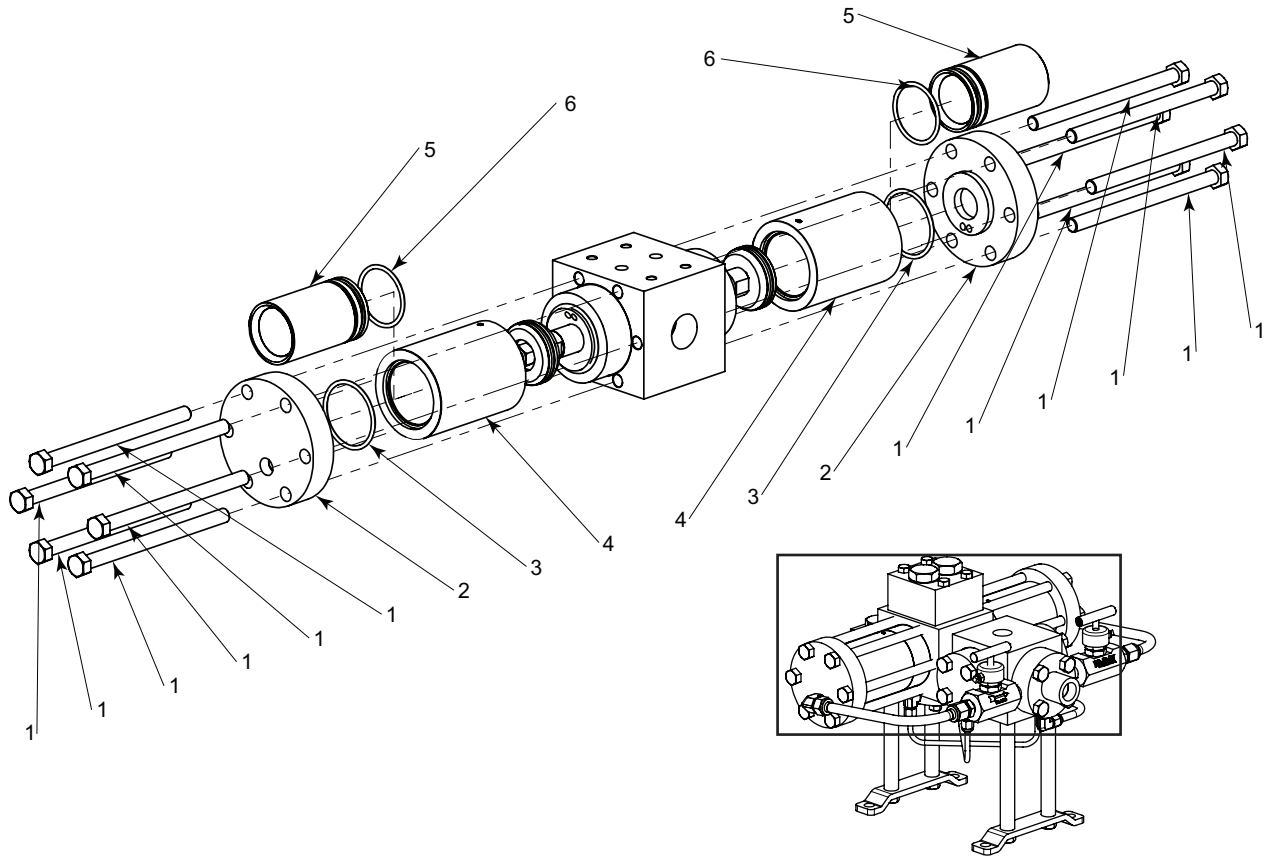

CYLINDER & CYLINDER HEAD ASSEMBLIES

ITEM	QTY.	DESCRIPTION	PART NUMBER							
			GPV020S	GPV040S	GPV050S	GPV090S	GPV100S	GPV200S	GPV210S	GPV450S
1	(Qty)	Bolt	782 (12)	782 (12)	783 (12)	783 (12)	784 (16)	1141 (16)	784 (16)	1141 (16)
2	2	Cylinder Head	785	785	786	786	787	1154	787	1154
3	2	O-Ring *	801HSN	801HSN	802HSN	802HSN	803HSN	1177HSN	803HSN	1177HSN
4	2	Cylinder	764	764	765	765	766	1505	766	2532
5	2	Cylinder Liner	2108	----	2373	----	2412	----	----	----
6	2	O-Ring *	773HSN	----	774HSN	----	329HSN	----	----	----
Repair Kits			RJD1-HSN	RJB1-HSN	RJH1-HSN	RJF1-HSN	RJK1-HSN	RJN1-HSN	RJ11-HSN	RJL1-HSN
			* These parts are recommended spare parts and are stocked as repair kits.							

GLYCOL PUMPS

ENERGY EXCHANGE
MODEL PV

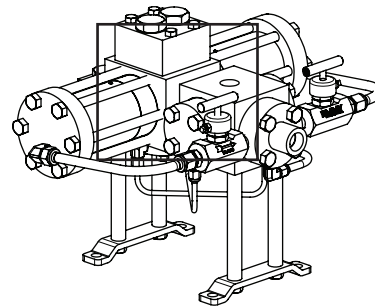

PISTON & PISTON ROD GLAND ASSEMBLIES

ITEM	QTY.	DESCRIPTION	PART NUMBER							
			GPV020S	GPV040S	GPV050S	GPV090S	GPV100S	GPV200S	GPV210S	GPV450S
1	2	Nut *	----	906	906	906	175	1140X	175	1140X
2	2	Piston	1506	776	776	777	1507	1508	778	1147
	2	Piston Set Screw	264	----	----	----	----	----	----	----
3	4	Back Up *	1513	1457	1457	1458	1458	772	772	1148
4	2	O-Ring *	156HSN	773HSN	773HSN	774HSN	774HSN	329HSN	329HSN	330HSN
5	2	O-Ring *	154HSN	154HSN	154HSN	154HSN	155HSN	1107HSN	155HSN	1107HSN
6	2	Piston Seal Retainer	1509	767	1510	768	1511	1512	769	1149
7	2	O-Ring *	801HSN	801HSN	802HSN	802HSN	803HSN	1177HSN	803HSN	1177HSN
8	2	Piston Rod Gland	954	954	927	927	790	1155	790	1155
9	4	O-Ring *	638HSN	638HSN	265HSN	265HSN	920HSN	1178HSN	920HSN	1178HSN
10	2	Pin	932	932	932	932	932	932	932	932
Repair Kits			RJD1-HSN	RJB1-HSN	RJH1-HSN	RJF1-HSN	RJK1-HSN	RJN1-HSN	RJI1-HSN	RJL1-HSN
			* These parts are recommended spare parts and are stocked as repair kits.							

All Pictures shown are for illustration purpose only. Actual product may vary due to product enhancement.
‡ Configuration of Glycol Pump is a trademark of Kimray, Inc.
www.kimray.com

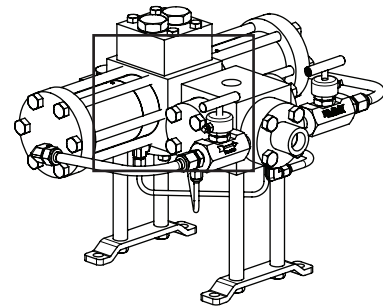
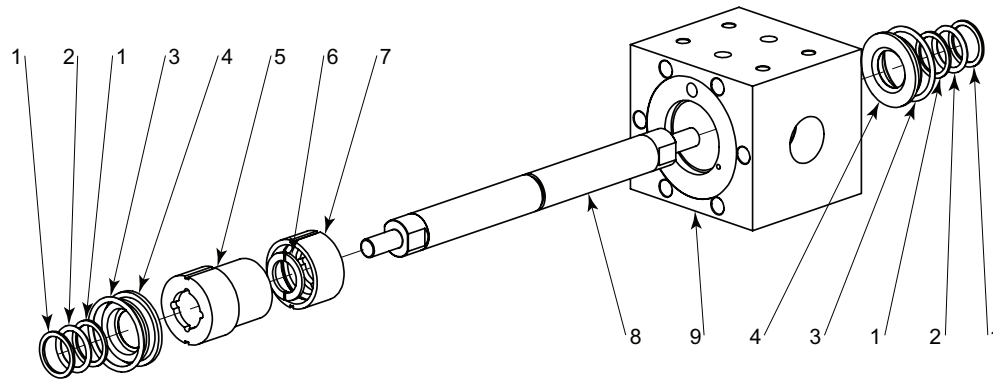

MAIN BLOCK, PISTON ROD & SEAL RETAINER ASSEMBLIES

ITEM	QTY.	DESCRIPTION	PART NUMBER							
			GPV020S	GPV040S	GPV050S	GPV090S	GPV100S	GPV200S	GPV210S	GPV450S
1	4	Back-up *	809	809	810	810	811	1157	811	1157
2	2	O-Ring *	807HSN	807HSN	156HSN	156HSN	808HSN	1180HSN	808HSN	1180HSN
3	2	O-Ring *	157HSN	157HSN	801HSN	801HSN	821HSN	1183HSN	821HSN	1183HSN
4	2	Piston Rod Seal Retainer	955	955	928	928	793	1156	793	1156
5	1	"D" Slid Actuator	795	795	796	796	797	1158	797	1158
6	1	Split Ring	838	838	839	839	840	1184	840	1184
7	1	Actuator Cap	835	835	836	836	837	1159	837	1159
8	1	Piston Rod	779	779	780	780	781	1165	781	1165
9	1	Main Piston Block	956	956	925	925	829	1164	829	1164
Repair Kits			RJD1-HSN	RJB1-HSN	RJH1-HSN	RJF1-HSN	RJK1-HSN	RJN1-HSN	RJI1-HSN	RJL1-HSN
			* These parts are recommended spare parts and are stocked as repair kits.							

NOTES:



Kimray is an ISO 9001- certified manufacturer.

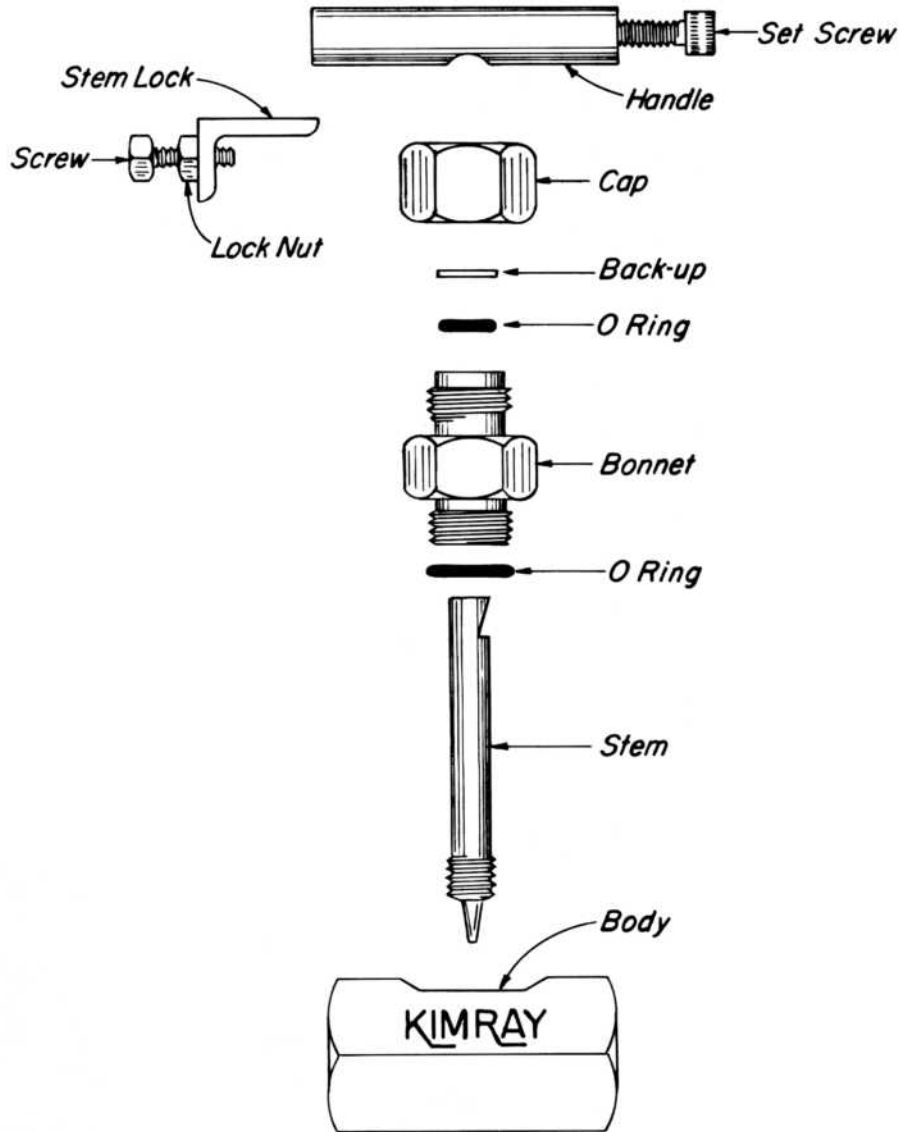

N.P.T. SIZE	VALVE NO.	ORIFICE SIZE	PUMP SIZE	BODY	BONNET	CAP	STEM	HANDLE	SET SCREW	BACK-UP	O-RING	O-RING	STEM LOCK	SCREW	LOCK NUT
TYPE 303 STAINLESS STEEL STANDARD ON ALL PUMPS EXCEPT 45020 PV PUMP															
1/4"	1911	1/16"	1720	1911A	1603D	1603F	1957A	1603B	1964	1978	638HSN	265HSN	6746	6731	6732
1/4"	1957	1/8"	4020	1957C	1603D	1603F	1957A	1603B	1964	1978	638HSN	265HSN	6746	6731	6732
3/8"	1956	3/16"	9020	1956C	1955D	1955F	1956A	1955B	1963	1979	153HSN	2631HSN	6747	6731	6732
1/2"	1955	9/32"	21020	1955C	1955D	1955F	1955A	1955B	1963	1979	153HSN	2631HSN	6747	6731	6732
CARBON STEEL STANDARD ON 45020 PV PUMP ONLY															
3/4"	1954	13/32"	45020	1954C	1954D	1954F	1954A	1954B	1962	1980	154HSN	2131HSN	6748	6731	6732

**ENERGY EXCHANGE
SPLIT DISCHARGE CHECK VALVE BLOCKS**

Kimray Glycol Pumps are available with check valve blocks for split discharge to serve two absorbers on a dehydration unit. On an original pump purchase there is no extra charge for this check block.

An accurately divided flow is assured since each absorber is served by one cylinder of the double acting pump.

For an installation of this type only one suction line is necessary. Also the high pressure wet glycol return may be manifolded through one filter or strainer to the pump.

When ordering any Kimray pump for this service, specify the pump number and service. For example: 4020 PV for "split discharge".

To order Check Valve Blocks for Split Discharge Assemblies add an "A" to the Check Valve Body number. Example: 1194A to order the assemblies with viton O-Rings add a "V" to Check Valve Assemblies number; Example: 1194AV

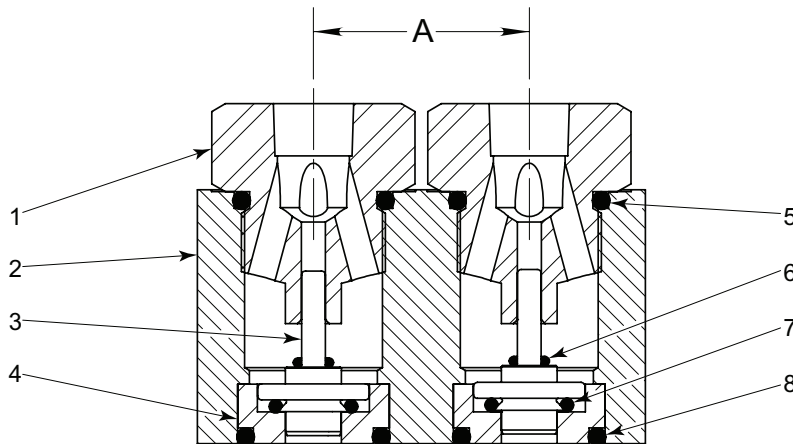

PART NUMBERS FOR INDICATED PUMPS							
ITEM NUMBER	PART NAME	QTY REQ'D	1720 PV	4020 PV and 2020 SC	9020 PV and 5020 SC	21020 PV and 10020 SC	45020 PV and 20020 SC
1	CHECK VALVE CAP	2	1327	1327	1114	1199	1198
2	CHECK VALVE BODY	1	1194	1194	1195	1196	1197
3	DART	2	1307	1307	853	854	1163
4	REMOVABLE SEAT	2	1152	1152	1131	1133	1173
5	"O" RING, CAP	2	155HSN	155HSN	156HSN	157HSN	801HSN
6	"O" RING, SNUBBER	2	647HSN	647HSN	647HSN	153HSN	265HSN
7	"O" RING, DART	2	855HSN	855HSN	154HSN	924HSN	156HSN
8	"O" RING, SEAT	2	491HSN	491HSN	1151HSN	156HSN	801HSN
TAPPED HOLE SIZE		NPT	1/4	1/4	3/8	1/2	3/4
DIMENSION "A"		Inches	1 1/2	1 1/2	1 11/16	2 5/16	3
ASSEMBLY			1194A	1195A	1196A	1197A	

All Pictures shown are for illustration purpose only. Actual product may vary due to product enhancement.

The small cylinder glycol pump was designed to extend the lower operating pressure of the pump downward from 300 psig to 100 psig. Due to increased gas consumption it is recommended to use the full cylinder pumps at pressures greater than 400 psig.

Any Kimray glycol pump can be field converted to a small cylinder pump of comparable size (see comparative table below). Likewise, small cylinder pumps can be converted to full cylinder pumps. The parts required for these conversions are stocked in kit form. To order conversion kits specify; (existing pump model) conversion kit to (converted pump model).

COMPARATIVE TABLE	
FULL CYLINDER	SMALL CYLINDER
GPV040S	GPV020S
GPV090S	GPV050S
GPV0210S	GPV0100S
GPV0450S	GPV0200S

REQUIRED CONVERSION PARTS					
PART DESCRIPTION	QTY	CAPACITY			
		040 TO 020	090 TO 050	210 TO 100	450 TO 200
Cylinder Liner	2	2108	2373	2412	1505
Piston	2	1506	776	1507	1508
Piston Seal Retainer	2	1509	1510	1511	1512
O-Ring	2	156HSN	773HSN	774HSN	329HSN
Back-up Ring	4	1513	1457	1458	772
O-Ring	2	154HSN	154HSN	155HSN	1107HSN
Lock Nut (Piston)	2	----	906	175	1140
Cylinder O-Ring	2	773	774	329	----

*The piston is the nut for this model and is furnished with a socket head set screw.

‡Full cylinder only.

‡Model 20020 SC only, requires 8, No. 772 Back-up rings.

GLYCOL PUMPS



ENERGY EXCHANGE CAPACITIES & DIMENSIONS

Model Number	Oper. Pressure		Gal. / Minute		Gal. / Hour		Strokes Minute		Glycol Output		GPH per Stroke / Minute
	Min.	Max.	Min.	Max.	Min	Max	Min	Max	Strokes/Gal.	Gal./Strokes	
GPV040S	300	2000	0.20	0.67	12	40	12	40	59	0.017	1.00
GPV090S	300	2000	0.45	1.50	27	90	12	40	26.3	0.038	2.25
GPV210S	400	2000	1.10	3.50	66	210	10	32	9	0.111	6.56
GPV450S	400	2000	2.77	7.50	166	450	10	28	3.5	0.283	16.07
GPV020S	100	500	0.13	0.33	8	20	5	55	147	0.0068	0.36
GPV050S	100	500	0.20	0.83	12	50	10	50	52	0.019	1.00
GPV100S	100	500	0.37	1.67	22	100	10	48	25	0.040	2.08
GPV200S	100	500	1.00	3.33	60	200	10	40	8.8	0.114	5.00

Model Number	Bore	Rod Diameter	Size of Pipe Connections	Mounting Bolts	Approx. Weight	Stroke
GPV040S	1.75"	0.75"	1/2" N.P.T.	3/8" Dia.	66 Lbs.	2.00"
GPV090S	2.25"	1.00"	3/4" N.P.T.	1/2" Dia.	119 Lbs.	2.75"
GPV210S	3.25"	1.38"	1" N.P.T.	1/2" Dia.	215 Lbs.	3.75"
GPV450S	4.50"	2.00"	1 1/2" N.P.T.	3/4" Dia.	500 Lbs.	5.13"
GPV020S	1.25"	0.75"	1/2" N.P.T.	3/8" Dia.	66 Lbs.	2.00"
GPV050S	1.75"	1.00"	3/4" N.P.T.	1/2" Dia.	119 Lbs.	2.75"
GPV100S	2.25"	1.38"	1" N.P.T.	1/2" Dia.	215 Lbs.	3.75"
GPV200S	3.25"	2.00"	1 1/2" N.P.T.	3/4" Dia.	500 Lbs.	5.13"

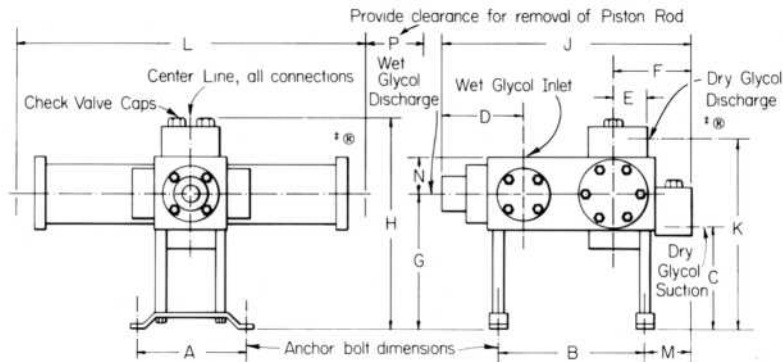

Model Number	Dimensions, Inches													
	A	B	C	D	E	F	G	H	J	K	L	M	N	P
GPV040S GPV020S	5 1/4	5 11/16	5 3/4	3 7/16	1 1/2	3 1/2	7 1/4	10 7/8	10 3/16	9 5/8	15	2 1/8	1 3/4	3
GPV090S GPV050S	6 1/4	8 1/4	6 3/8	5	1 3/4	4 1/4	8 3/4	13 1/4	13 7/8	11 3/4	20	2 1/2	2	3
GPV210S GPV100S	7 5/8	10 1/8	7	5 3/8	2 1/4	5 3/4	9 1/4	14 3/4	16 5/8	13	24	3 3/16	2 1/2	4
GPV450S GPV200S	10 3/4	14	9	6 5/8	2 5/8	6 1/2	11 3/8	19	21 1/8	16 3/8	34	3 3/4	3 1/2	6

All Pictures shown are for illustration purpose only. Actual product may vary due to product enhancement.
 ‡ Configuration of Glycol Pump is a trademark of Kimray, Inc.
www.kimray.com

GAS CONSUMPTION FULL CYLINDER																		
Operating Pressure --p.s.i.g.	300	400	500	600	700	800	900	1000	1100	1200	1300	1400	1500	1600	1700	1800	1900	2000
Cu. Ft./Gallon @ 14.4 & 60°F.	1.7	2.3	2.8	3.4	3.9	4.5	5.0	5.6	6.1	6.7	7.2	7.9	8.3	8.7	9.3	9.8	10.4	10.9

CIRCULATION RATE GRAPH FULL CYLINDER

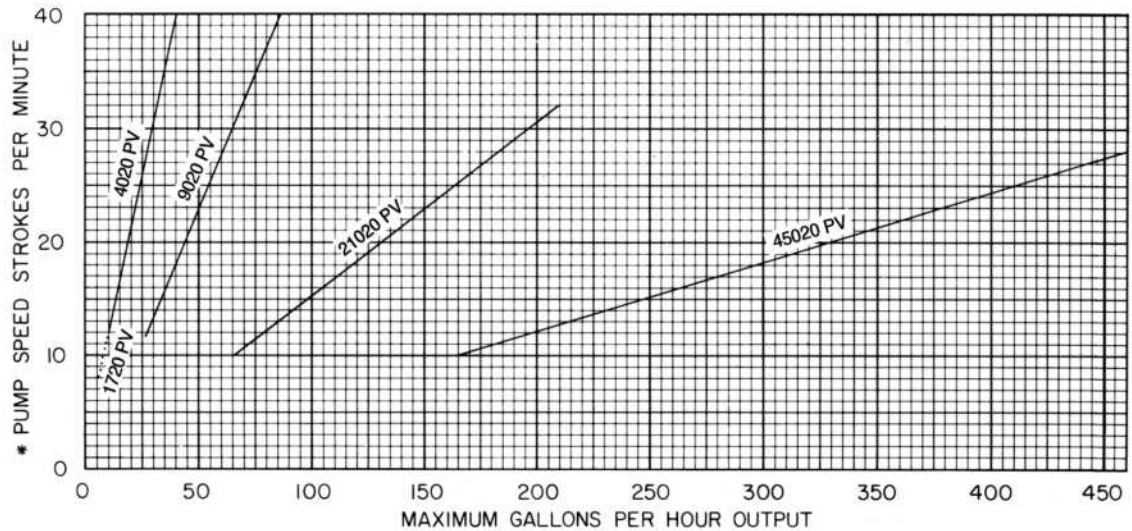

* It is not recommended to attempt to run pumps at speeds less or greater than those indicated in the above graph.

CIRCULATION RATE GRAPH SMALL CYLINDER

GAS CONSUMPTION SMALL CYLINDER				
Operating Pressure --p.s.i.g.	100	200	300	400
Cu. Ft./Gallon @ 14.4 & 60°F.	1.0	1.9	2.8	3.7

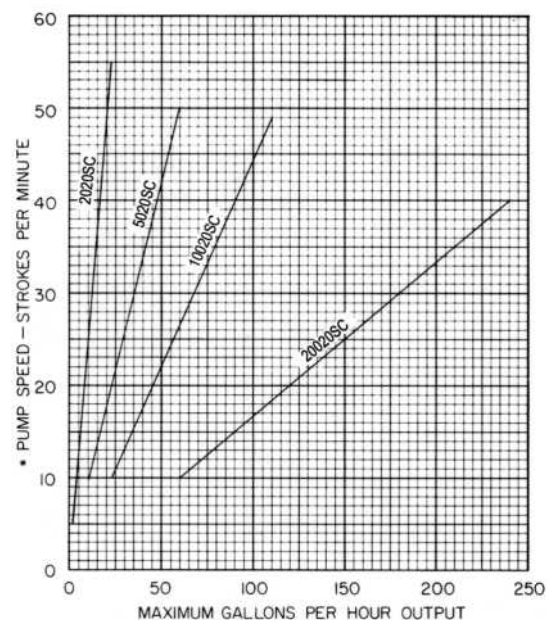

* It is not recommended to attempt to run pumps at speeds less or greater than those indicated in the above graph.

ENERGY EXCHANGE
OPERATING PARAMETERS

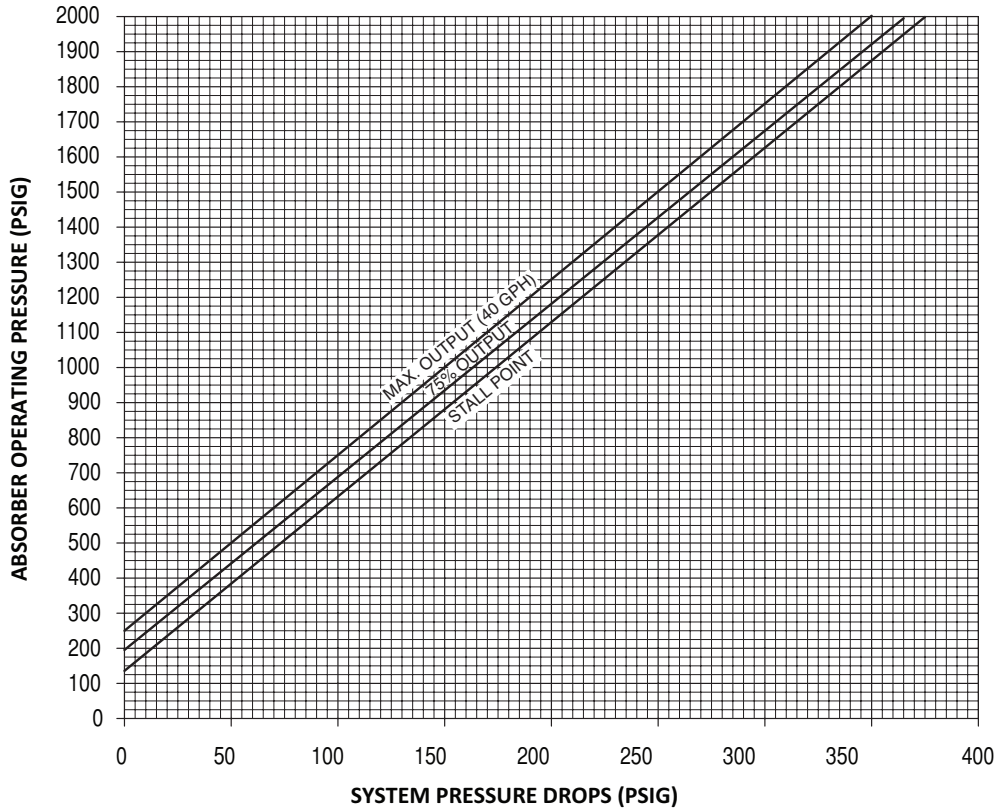

4020 PV Strokes/Minute Range 12-40

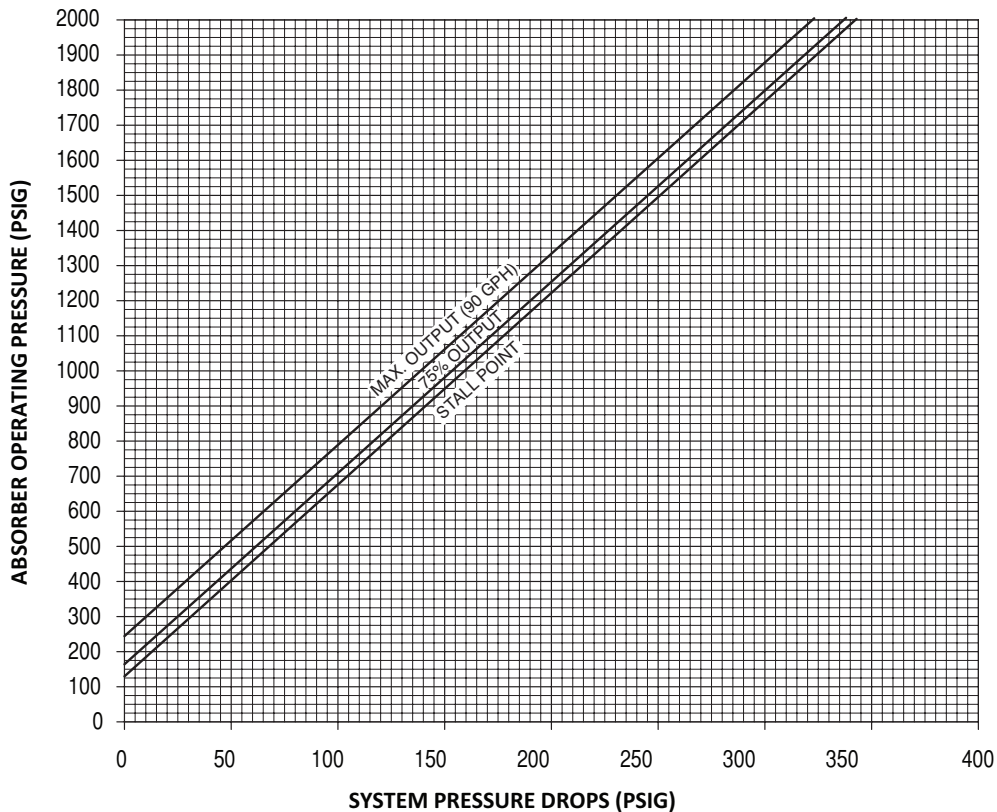

9020 PV Strokes/Minute Range 12-40

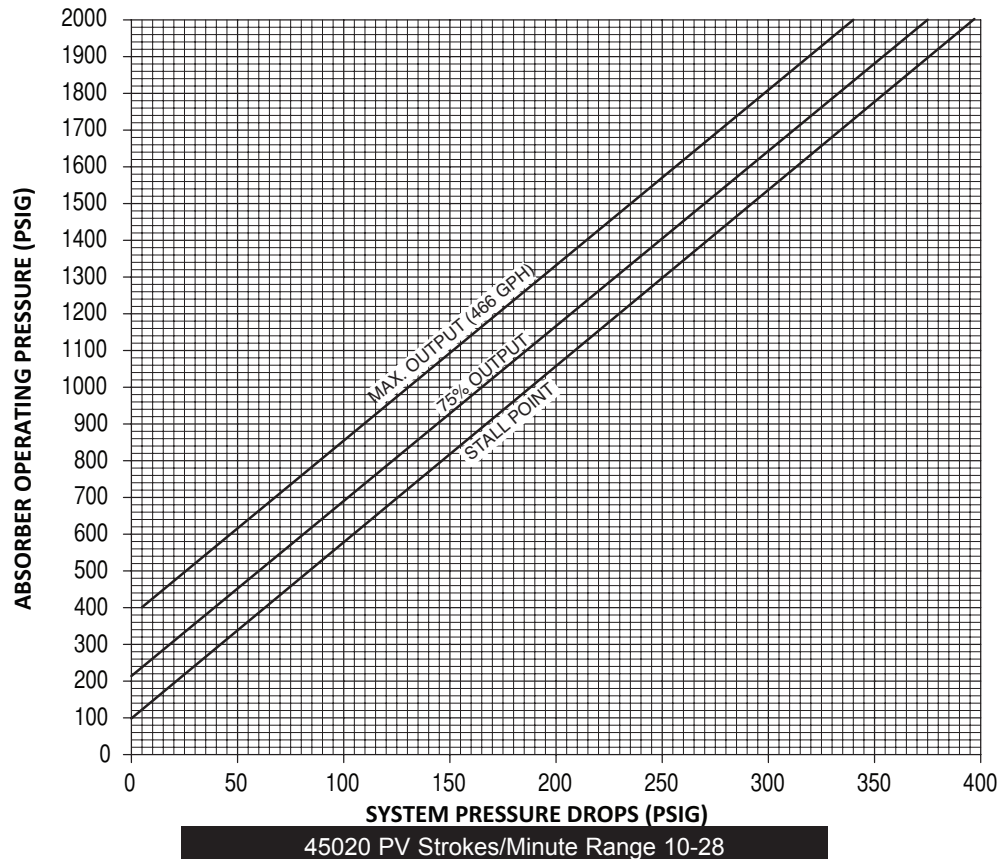
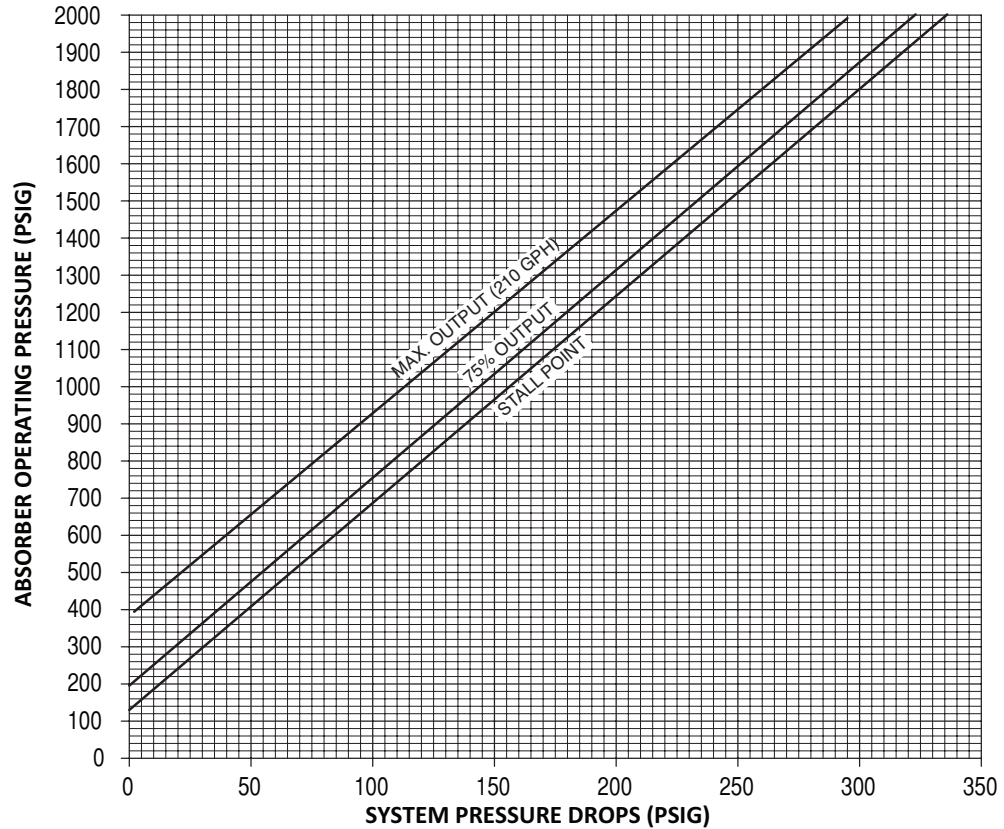

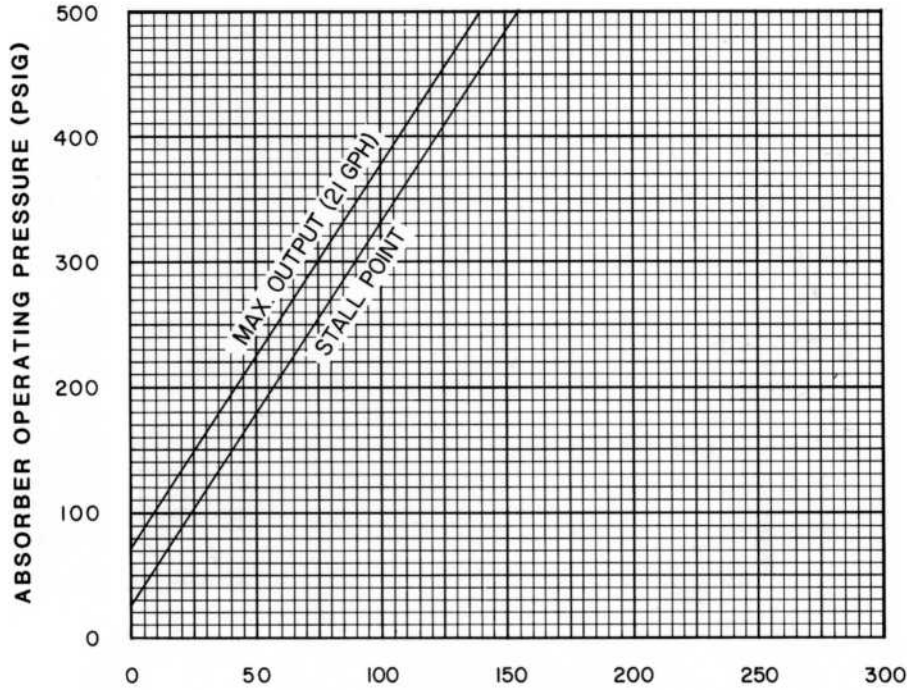

SYSTEM PRESSURE DROPS (PSIG)

2020 SC Strokes/Minute Range 5-55

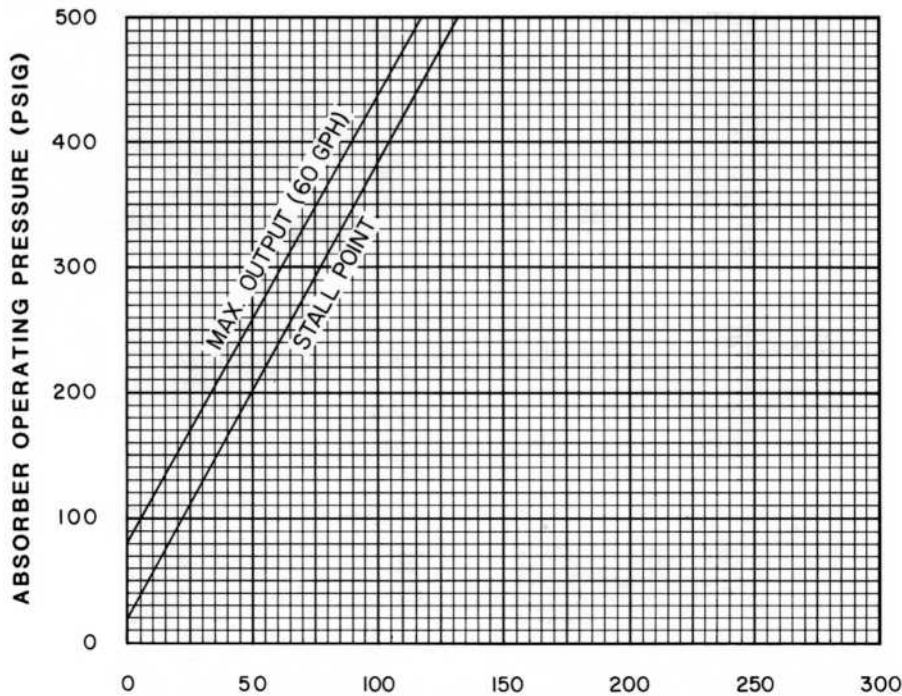

SYSTEM PRESSURE DROPS (PSIG)

5020 SC Strokes/Minute Range 10-50

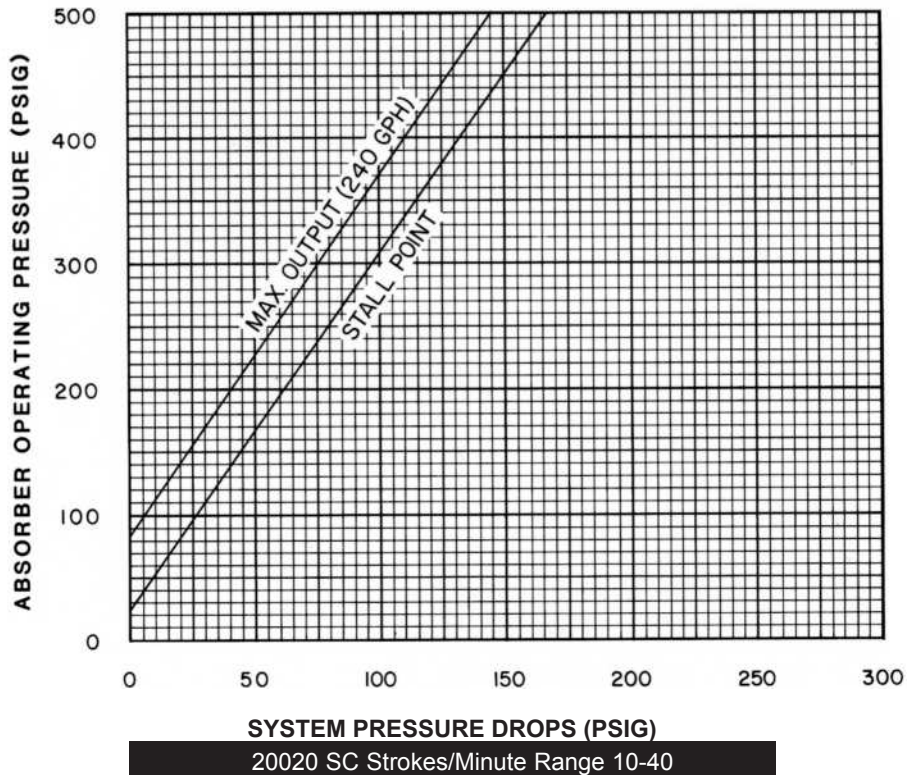
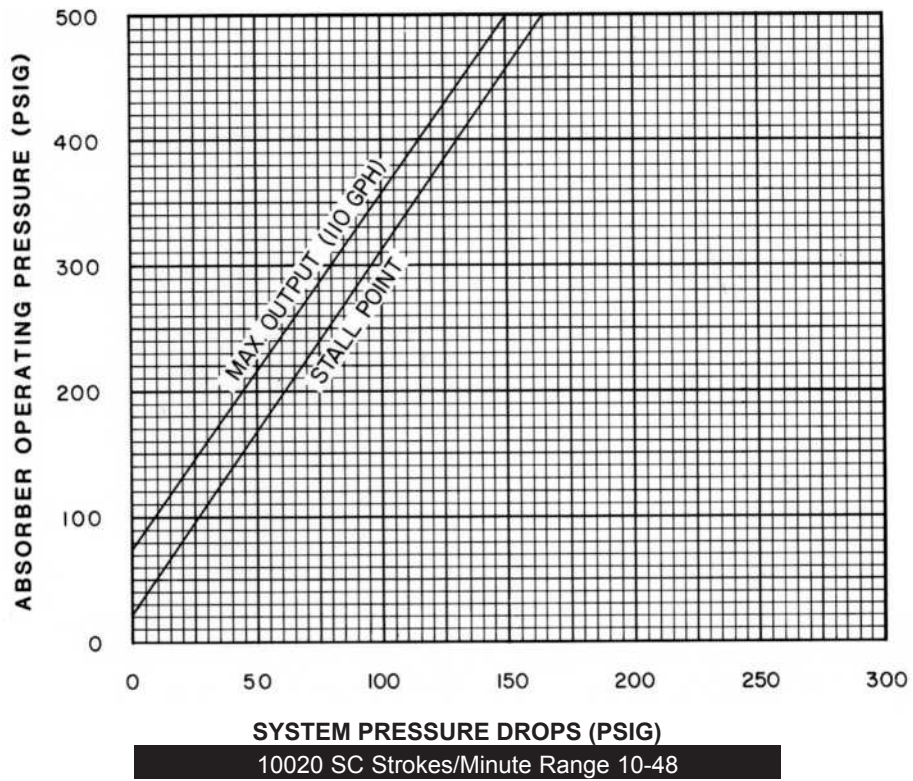

Table 1 - Seal Options		
Part	Standard Material	Optional Material
O-rings	HSN	FKM, Aflas®
Backups	Glass Filled Teflon	-----

Table 2 - Seal Specifications				
		HIGHLY SATURATED NITRILE	FKM	AFLAS®
Kimray Suffix		HSN	V	AF
Resistance	Abrasion	G-E	G	G
	Acid	G-E	G-E	E
	Chemical	F	E	E
	Cold	G	P	P
	Flame	P	E	E
	Heat	E	E	E
	Oil	E	E	E
	Ozone	G	G-E	E
	Set	G	G-E	P
	Tear	F	F	P
	Water/Steam	E	P	G
	Weather	G	E	E
	CO2	G	G	G
	H2S	F	P	E
Methanol	E	P	P	
Properties	Dynamic	G	G	G
	Electrical	F	F	G-E
	Impermeability	G	G	G
	Tensile Strength	G-E	G	F
Temp. Range		-20° to +250°F	-15° to +400°F	+15° to +450°F
		-29° to +121°C	-26° to +204°C	-9° to +232°C
RATINGS: P-POOR, F-FAIR, G-GOOD, E-EXCELLENT				

Table 3 - Material Options

Component	Standard Material	Optional Material
Body	Ductile (ASTM A395)	N/A
Suction Block	Ductile (ASTM A395)	N/A
Discharge Block	Ductile (ASTM A395)	N/A
Main Valve Housing	Ductile (ASTM A395)	N/A
Pilot Valve Housing	Ductile (ASTM A395)	N/A
Port Plates	Stellite No 6	N/A
Cylinder Heads	Ductile (ASTM A395)	N/A
Pilot Piston Caps	Ductile (ASTM A395)	N/A
Cylinders	17-4PH (ASTM A564)	N/A
Pistons	Alloy Steel (ASTM A108)	N/A
Pilot Pistons	17-4PH (ASTM A564)	N/A
Piston Rod	17-4PH (ASTM A564)	N/A
Piston Rod Glands	Ductile (ASTM A395)	N/A
Fittings	Steel (ASTM A108)	316SS (ASTM A479)
Tubing	304SS (ASTM A249)	N/A

Table 4 - Material Specification

	Body		Inner Parts		
	CAST STEEL	CAST DUCTILE	303 STAINLESS STEEL	316 STAINLESS STEEL	6061-T6 ALUMINUM
KIMRAY SUFFIX	LCB	C6	S3	S6	AL
ASTM GROUP	ASTM A-352	ASTM A-351	ASTM A-582	ASTM A-479	ASTM B-221
GRADE	LCB	CF8M	303	316	6061-T6
UNS	J02505	J92900	S30300	S31600	A96061
NACE Compliant	Yes	Yes	No	No	No

NOTES:



Kimray is an ISO 9001- certified manufacturer.

APPLICATIONS:

- Circulating pump for gas glycol dehydrators, gas amine units and other pumping applications.

FEATURES:

- No Gas Emissions
- No Packing
- Hydraulically Balanced Diaphragms
- Double-ended Shaft
- Stud Extenders for easy Head Installation
- Pulse-Free flow
- Direct or Belt Driven

CERTIFICATIONS:

Kimray is an ISO 9001- certified manufacturer.

SPECIFICATIONS:

- Capacity @ max. pressure:

rpm	gpm	l/min
1500 psi (103 bar)	1200	8.3
1200		31.4
- RPM: 1200 max.- 200 min.
- Inlet: 250 psi max
- Connections:
 - Inlet: 1" NPT
 - Outlet: 3/4" NPT
- Temperature:
 - Max: 230° F (110° C)
 - Min: 40° F (4.4° C)
 - [contact factory for temperatures below 40° F (4.4° C)]
- Fluid End Material,
 - Manifold : Ductile Iron ASTM A536-84, Grade 65-45-12
 - Crankcase: Ductile Iron ASTM A536-84, Grade 65-45-12
- Elastomers: Highly Saturated Nitrile
- Oil Capacity: 2.75 quarts KIMRAY Part No. 7266
2.60 Liters
- Weight (dry): 100 lbs (45.7 kg)
- Bi Directional Shaft Rotation

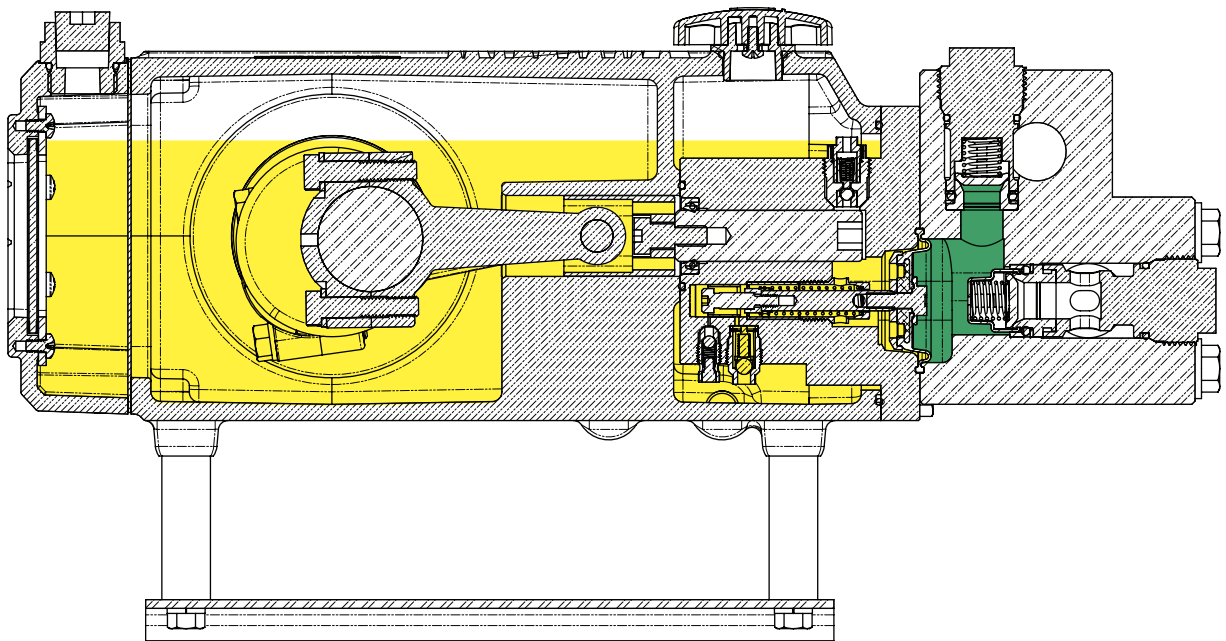
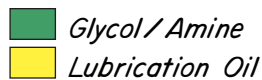

Standard Configuration Code †	Order Code	Gallons per hour Minimum	Gallons per hour Maximum ††	Operating Pressure Minimum	Operating Pressure Maximum
GEV500S	GEA	90	500	0	1500

NOTES:

† For code builder see page 10:00.3

†† Maximum output is affected by system pressure drops. See system operation parameter for maximum output curves.

Component Identification

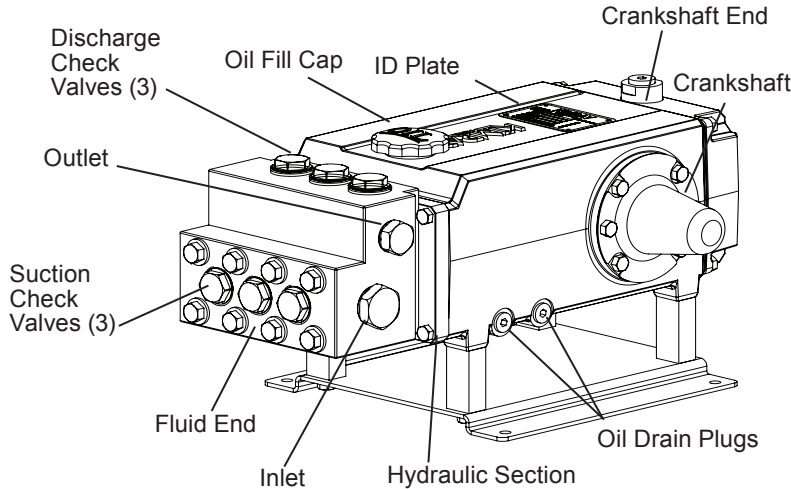

LOCATION

Locate the pump as close to the fluid supply source as possible. Allow room for checking the oil level, changing the oil (two drain plugs on the bottom and back of pump), and removing the pump head components (inlet and discharge retainer plates, manifold, and related items).

MOUNTING

The pump shaft can rotate in either direction. To prevent vibration, mount the pump and motor securely on a level rigid base. On a belt-drive system, align the sheaves accurately; poor alignment wastes horsepower and shortens the belt and bearing life. Make sure the belts are properly tightened, as specified by the belt manufacturer. On a direct-drive system, align the shafts accurately. Unless otherwise specified by the coupling manufacturer, maximum parallel misalignment should not exceed 0.015 in. (0.4 mm) and angular misalignment should be held to 1° maximum. Careful alignment extends life of the coupling, pump, shafts, and support bearings. Consult coupling manufacturer for exact alignment tolerances.

ACCESSORIES

Consult installation drawing above for typical system components. Contact KIMRAY INC. or the distributor in your area for more details.

REPAIR KITS AVAILABLE:

CAT. NO.	TYPE	MATERIAL
RZAHSN	CHECK VALVE REPAIR KIT	HIGHLY SATURATED NITRILE
RZBHSN	COMPLETE REPAIR KIT	HIGHLY SATURATED NITRILE
RZCHSN	DIAPHRAGM REPAIR KIT	HIGHLY SATURATED NITRILE

OIL AVAILABLE:

CAT. NO.	TYPE	CAPACITY QUARTS	CAPACITY LITERS
7266	EGP1 KIMZOIL	2.75	2.60

IMPORTANT PRECAUTIONS

Adequate Fluid Supply. To avoid cavitation and premature pump failure, be sure that the pump will have an adequate fluid supply and that the inlet line will not be obstructed.
Positive Displacement. This is a positive-displacement pump. Install a relief valve downstream from the pump.
Safety Guards. Install adequate safety guards over all pulleys, belts, and couplings. Follow all codes and regulations regarding installation and operation of the pumping system.
Shut-Off Valves. Never install shut-off valves between the pump and discharge pressure regulator, relief valve, or in the regulator bypass line.
Freezing Conditions. Protect the pump from freezing. See also the Maintenance Section.
 Consult the Factory for the following situations:

- Extreme temperature applications – above 250° F (82° C) or below 40° F (4.4° C)
- Viscous fluid applications above 100 Cps
- Chemical compatibility problems
- Hot ambient temperatures – above 110° F (43° C)
- Conditions where pump oil may exceed 200° F (93° C) because of a combination of hot ambient temperatures, hot fluid temperature, and full horsepower load — an oil cooler may be required
- Pump RPM less than 200

CALCULATING REQUIRED HORSEPOWER (KW)*

$$\frac{\text{gpm} \times \text{psi}}{1,460} = \text{electric motor HP}^*$$

$$\frac{\text{lpm} \times \text{bar}}{511} = \text{electric motor kW}^*$$

* HP/kW is required application power.

ATTENTION!

When sizing motors with variable speed drives (VFDs), it is very important to select a motor and a VFD rated for constant torque inverter duty service and that the motor is rated to meet the torque requirements of the pump throughout desired speed range.

All Pictures shown are for illustration purpose only. Actual product may vary due to product enhancement.

Performance

50015 EV Performance

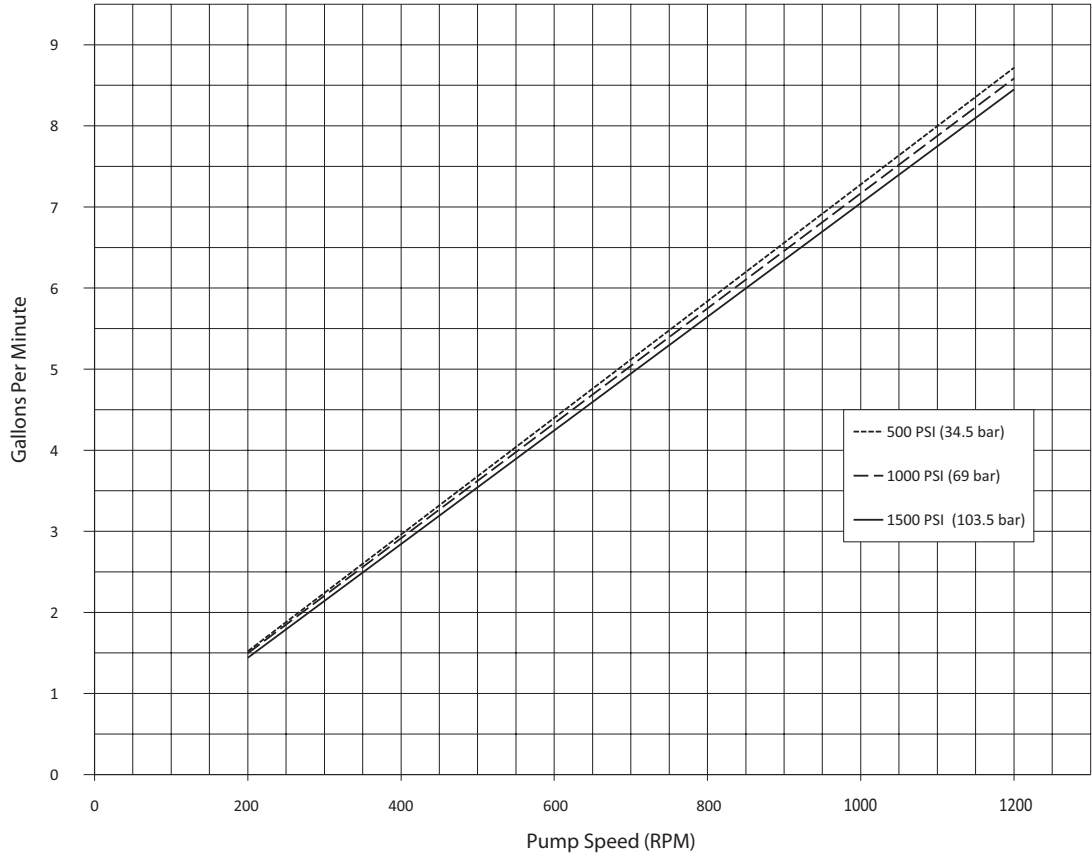

Net Positive Suction Head – NPSHr

Net Positive Suction Head (NPSHr)

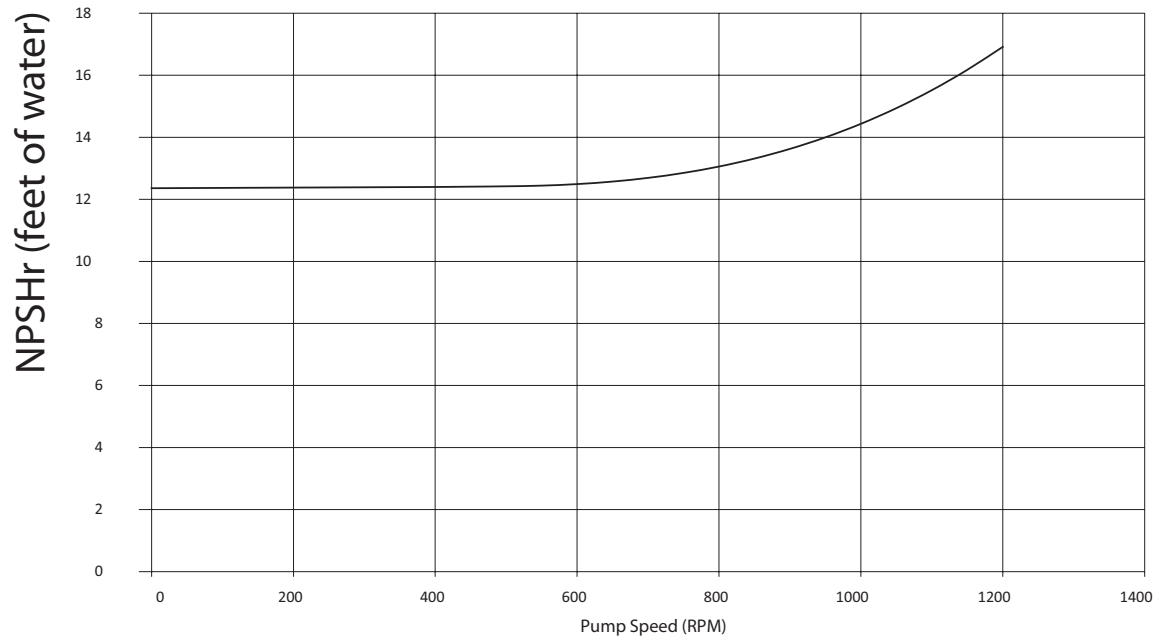

GLYCOL PUMPS



ELECTRIC PUMP MODEL EV - PARTS

ITEM NO.	PART NUMBER	DESCRIPTION	QTY.	KIT
1	189-401-02	CRANKCASE, T9, MACHINING	1	
2	189-511	PLATE, DATA	1	
3	172-102-02	CRANKSHAFT, FINISHED	1	
4	189-509	ROD, CONNECTING, ASSEMBLED	3	
	189-507	ROD, FRONT CONNECTING	1	
	189-508	ROD, REAR CONNECTING	1	
	189-510	PIN, DOWEL .125	2	
	189-522	SCREW, 5/16-18 UNC-2A X 1.375, HHCS	2	
	C22-014-2000	WASHER, M8 SPLIT LOCK	2	
5	172-004	BEARING, SPHERICAL ROLLER, 22206	2	
6	N10-073-2110	O-RING, BUNA, -150	2	
7	189-545	MACHINING, BEARING CARRIER	2	
8	189-525	SCREW, 5/16-18 UNC-2A, HHCS	14	
9	F20-031-2110	SEAL, BUNA	4	
10	189-500	COVER, CRANKSHAFT	1	
11	189-054	PIN, WRIST	3	
12	189-528	SCREW, SHOULDER, 5/16-18 UNC-2A, SHCS	3	
13	189-437	CROSSHEAD	3	
14	189-431	PLUNGER, .787	3	
15	189-520	SPACER, BASE PLATE 256 TC	4	
16	189-502-01	BRACKET, MOUNTING	1	
17	C22-014-2000	WASHER, M8 SPLIT LOCK	4	
18	189-032	PLUG, 3/8 SAE, STEEL	2	
19	189-521	SCREW, 5/16-18 UNC-2B X 2.75, HHCS	4	
20	D15-037-2110	O-RING, BUNA-N, -164	1	
21	D03-026-2210	PIN, DOWEL, 5/16"	2	
22	D10-080-21XX	MATRIX, .862 ID X .103 WIDE O-RING	1	
23	189-595-XX	ASSY, METAL OIL CAP	1	
	189-590-XX	BASE, OIL CAP	1	
	189-591-XX	TOP, OIL CAP	1	
	189-595	SCREW, PHMS 0.164-32x0.375x0.375-S	1	

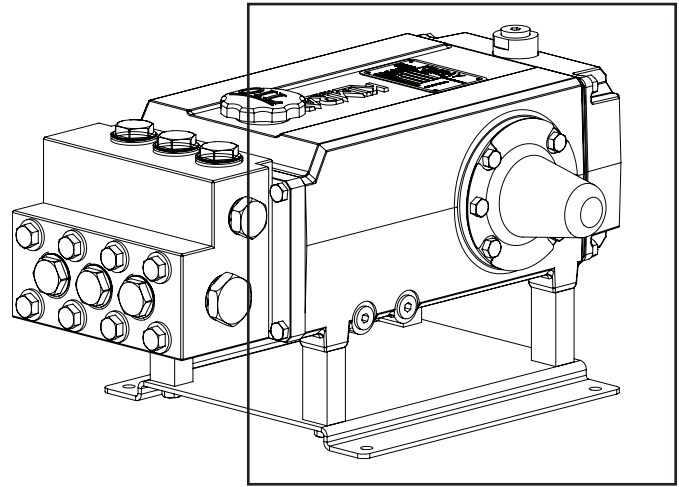

ITEM NO.	PART NUMBER	DESCRIPTION	QTY.	KIT
24	189-560-02	COVER, LEVEL SWITCH	1	
25	189-553	GASKET	2	
26	189-552	GLASS, SIGHT	1	
27	189-556	FRAME, SIGHTGLASS	1	
28	189-565	SCREW, 10-24 PAN HEAD	6	
29	189-564	GASKET, REAR COVER, K9	1	
30	C63-026-2118	O-RING, C62 REGULATOR BODY, -119	1	
31	189-561	ADAPTER, INTERNAL FLOAT SWITCH	1	
32	189-313	PLUG, 1/2 INCH NPT	1	

Items denoted with a 1 are part of Valve Kit
 Items denoted with a 2 are part of Complete Kit
 Items denoted with a 3 are part of Diaphragm Kit

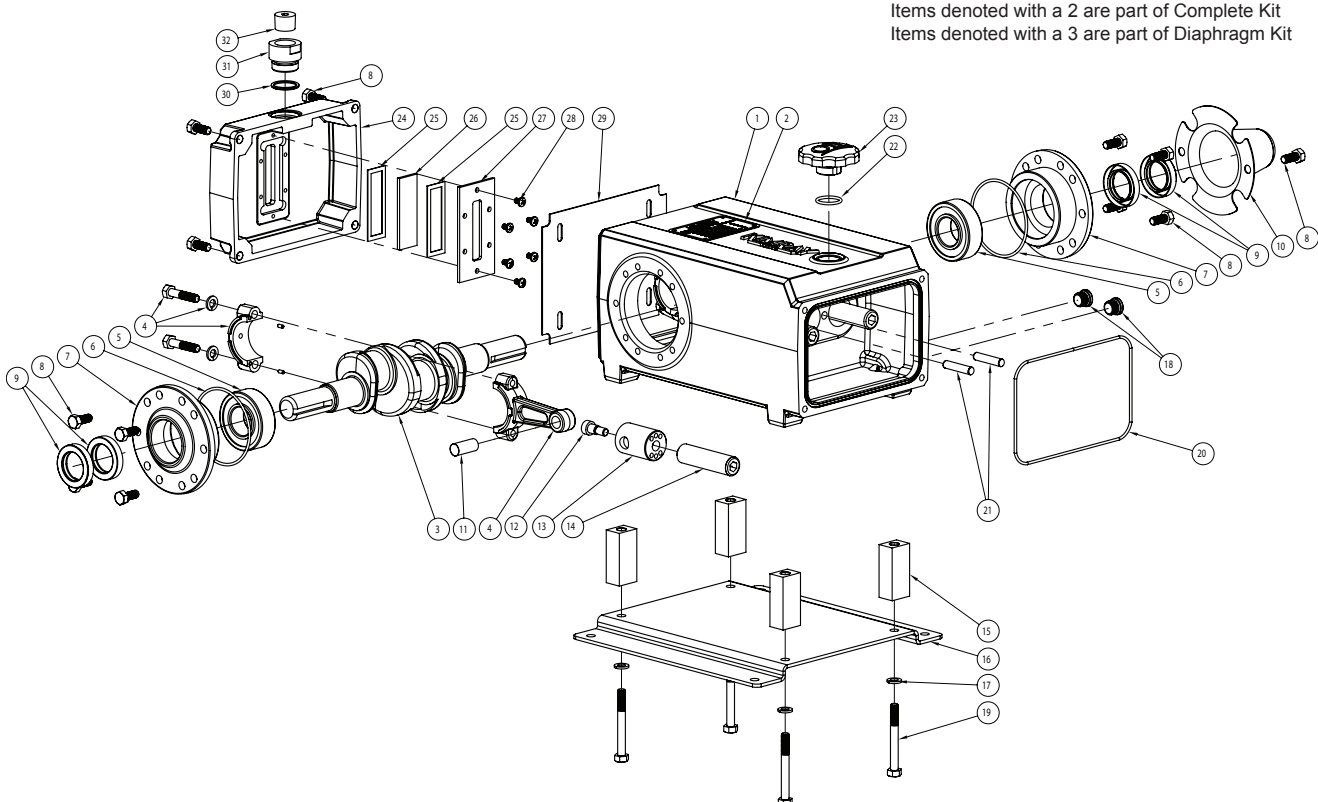

All Pictures shown are for illustration purpose only. Actual product may vary due to product enhancement.

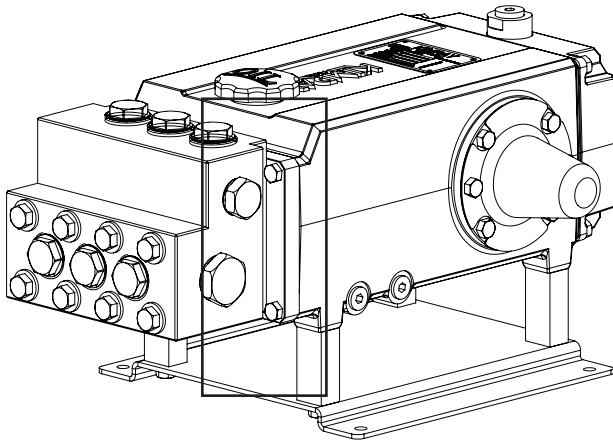

ITEM NO.	PART NUMBER	DESCRIPTION	QTY.	KIT
33	189-403	PLATE, DIAPHRAGM, MACHINED BILLET 9L	2	
34	177-906	CARTRIDGE	3	
	177-119	PLUG	1	
	172-016	BALL, 3/16 DIAMETER	1	
	172-017	SEAT,	1	
	172-118	PIN	1	
	172-061	SPRING, OVERFILL VALVE	1	
	172-119	RETAINER	1	
35	177-905	CARTRIDGE, OVERFILL VALVE	3	
	177-017	OVERFILL SEAT	1	
	172-016	BALL, 3/16 DIAMETER	1	
	172-061	SPRING, OVERFILL VALVE	1	
	177-018	RETAINER, OVERFILL SPRING	1	
36	177-904	CARTRIDGE, UNDERFILL VALVE	3	
	177-160	SEAT, UNDERFILL	1	
	172-161	CAGE, UNDERFILL	1	
	172-061	SPRING, OVERFILL VALVE	1	
	177-075	PIN, STOP	1	
	D25-015-3010	BALL, .250 DIA. ALLOY STEEL	1	
	189-594	CLIP, RETAINING	1	
37	189-451	SCREW, #10-24 UNC-2B x .625, SHSS	3	
38	189-429	VALVE, SPOOL, HOLLOW	3	
39	189-317	STOP, SPOOL	3	
40	189-316	WASHER, GUIDE	3	
41	189-452	ROD, BIAS SPRING, TAPERED	3	
42	189-558	SPRING, BIAS	3	
43	189-141	RETAINER, BIAS SPRING	3	
44	189-454	CLAMP, DIAPHRAGM, 9L	3	
45	189-125-01	DIAPHRAGM, INSERT MOLDED, 9L, HSN	3	2 & 3
46	177-144-01	SCREW, DIAPHRAGM FOLLOWER	3	
47	D03-073-2131	O-RING, -2131 (FKM)	1	
48	189-438	SEAL, SHAFT	3	
49	189-512	SCREW, 5/16-18 UNC-2B X 1.125, HHCS	4	

Items denoted with a 1 are part of Valve Kit
 Items denoted with a 2 are part of Complete Kit
 Items denoted with a 3 are part of Diaphragm Kit

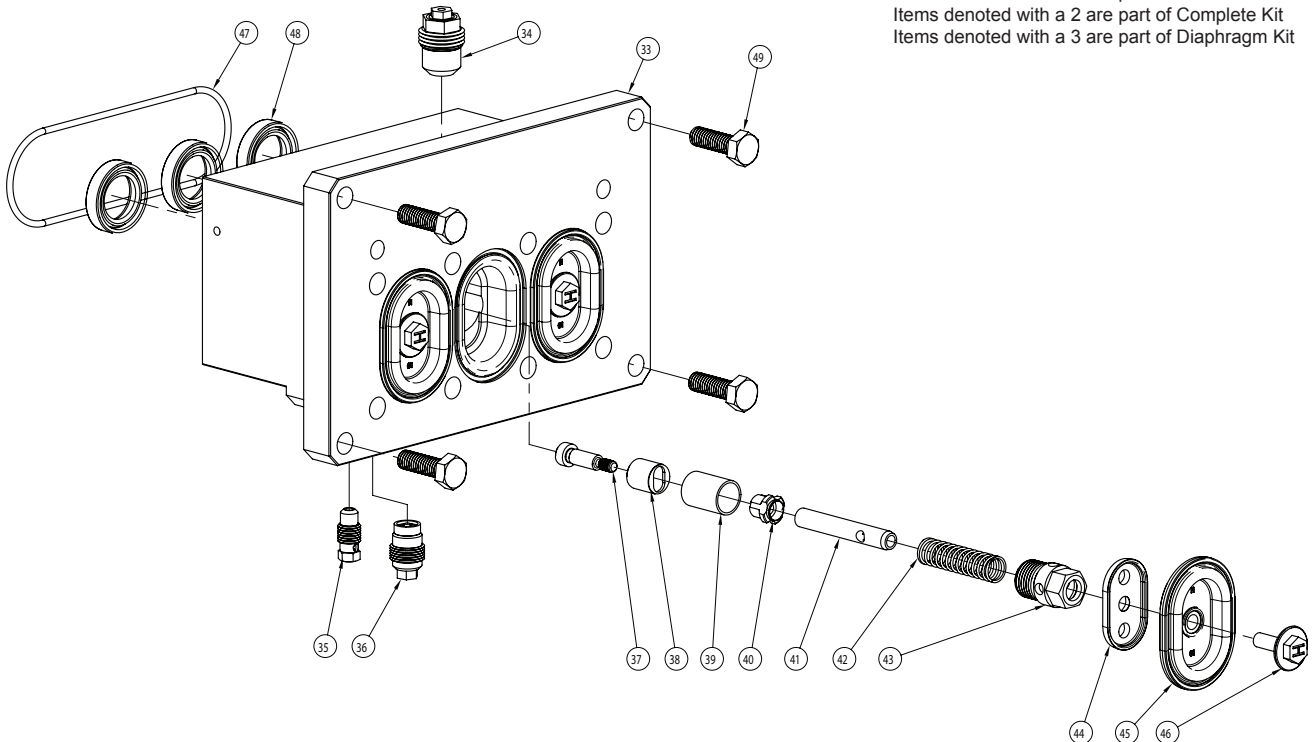

All Pictures shown are for illustration purpose only. Actual product may vary due to product enhancement.

GLYCOL PUMPS

ELECTRIC PUMP MODEL EV - PARTS

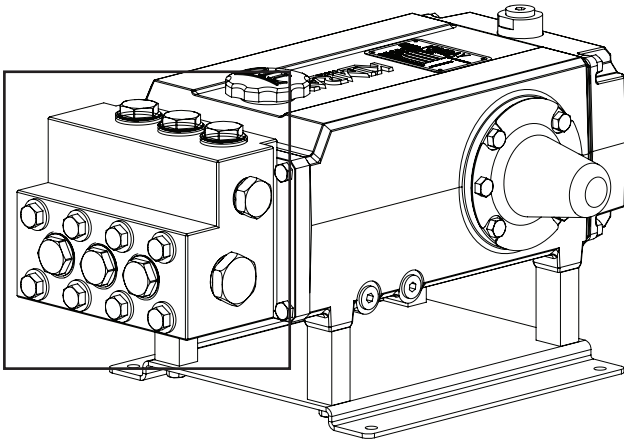

ITEM NO.	PART NUMBER	DESCRIPTION	QTY.	KIT
50	189-406-XX	MANIFOLD, K9L MACHINED	1	
51	189-311	PLUG, 3/4 NPT SST	1	
52	189-312	PLUG, 1 NPT SST	1	
53		VALVE, BAYONET OUTLET CHECK, ASSY	3	
	189-549-01	SEAT, OUTLET BAYONET VALVE, 9M	1	1 & 2
	189-233	RING, BACKUP, -212, PTFE	2	1 & 2
	189-232	O-RING, -211, VITON	1	1 & 2
	189-215-01	DISC, VALVE	1	1 & 2
	189-414	SPRING	1	1 & 2
54	189-234-01	O-RING, BUNA, -120	6	1 & 2
55	189-548	PLUG, OUTLET CV, SST	3	
56		VALVE, BAYONET INLET CHECK, ASSY	3	
	189-418	RETAINER, T9L METALLIC SPRING	1	1 & 2
	189-414	SPRING	1	1 & 2
	189-215-01	DISC, VALVE	1	1 & 2
	189-448	RING, CV RETAINER, 9M	1	1 & 2
	189-233	RING, BACKUP, -212, PTFE	1	1 & 2
	189-232-01	O-RING, -211, BUNA	1	1 & 2
	189-547-01	SEAT, INLET BAYONET VALVE, 9M	1	1 & 2
57	189-546	PLUG, INLET CV, SST	3	
58	189-540	WASHER, 7/16 BOLT, EXTREME STRENGTH	8	
59	189-539	BOLT, HEX HEAD, 7/16-14	8	

Items denoted with a 1 are part of Valve Kit
 Items denoted with a 2 are part of Complete Kit
 Items denoted with a 3 are part of Diaphragm Kit

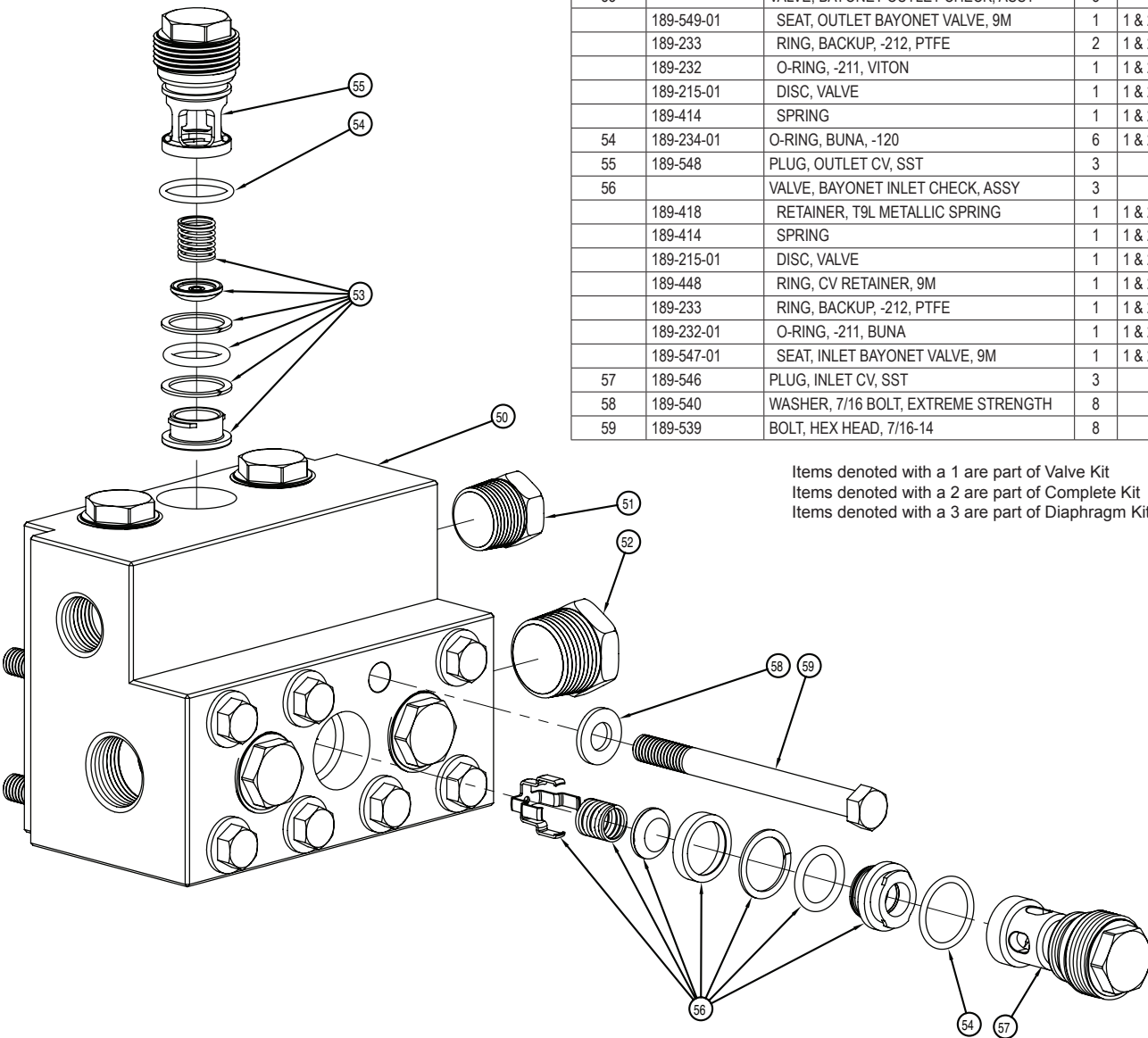

All Pictures shown are for illustration purpose only. Actual product may vary due to product enhancement.

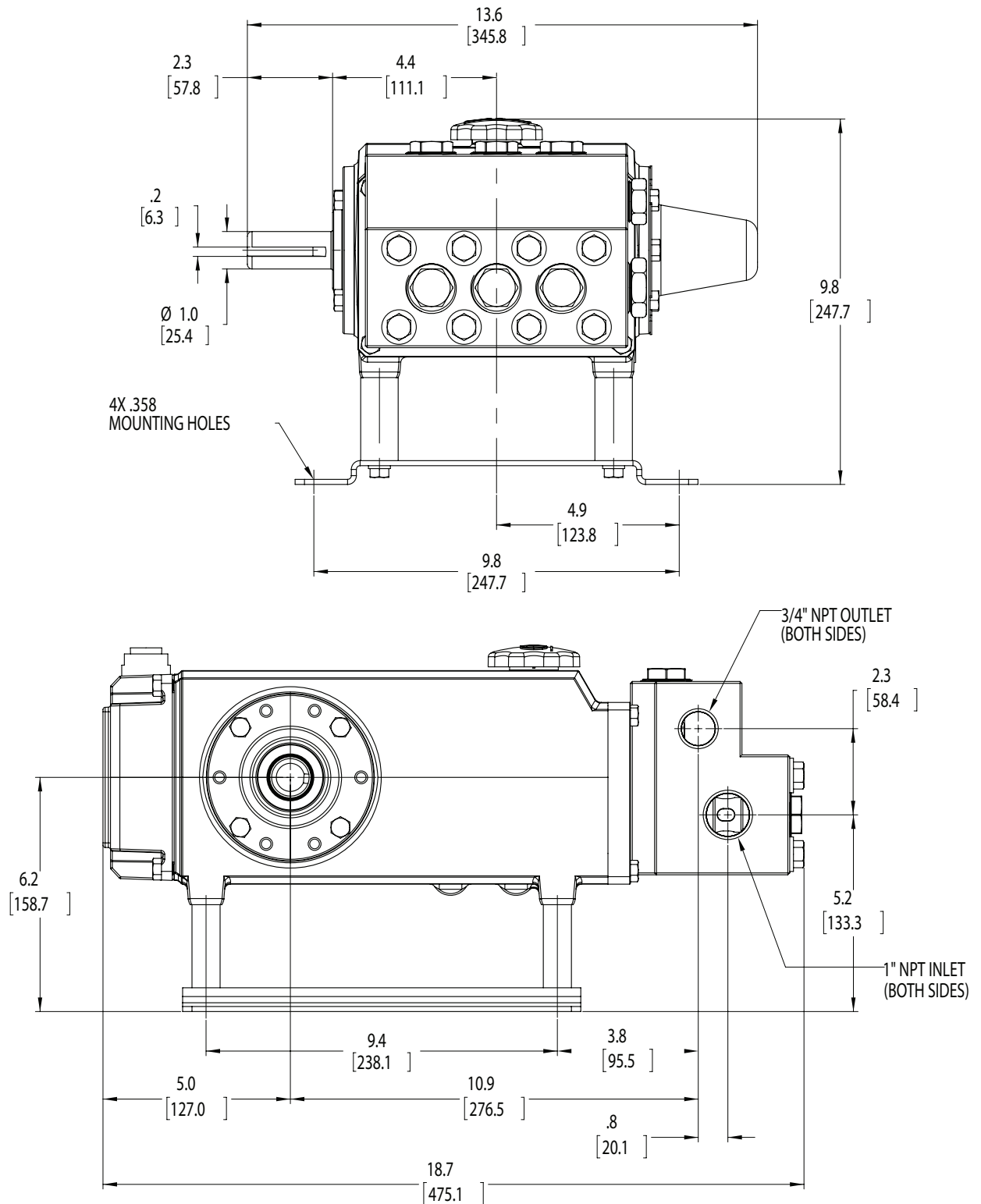

All Pictures shown are for illustration purpose only. Actual product may vary due to product enhancement.

NOTES:



Kimray is an ISO 9001- certified manufacturer.

APPLICATIONS:

- Circulating pump for gas glycol dehydrators, gas amine units and other pumping applications.

FEATURES:

- No Gas Emissions
- No Packing
- Hydraulically Balanced Diaphragms
- Inline Service
- Pulse-Free flow
- Direct Driven

SPECIFICATIONS:

- Capacity @ max. pressure:

rpm	gpm	l/min	
1200 psi (83 bar)	1750	2.2	8.3
- RPM: 1750 max.- 200 min.
- Inlet
 - 250 psi max
- Connections:
 - Inlet: 1/2" NPT
 - Outlet: 3/8" NPT
- Temperature:
 - Max: 230° F (121.1° C)
 - Min: 30° F (4.4° C)
- Fluid End Material, Manifold : SA395 / SA479
- Elastomers: HNBR
- Oil Capacity: 1 Quart KIMRAY Part No. 7266
0.95 Liters
- Weight (dry): 37 lbs (16.8 kg)
- Bi Directional Shaft Rotation
- For use with NEMA 56c Footed Motor only

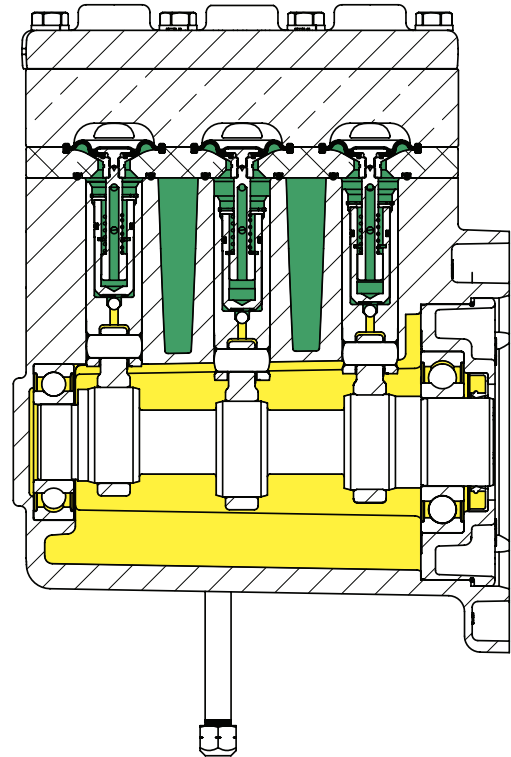
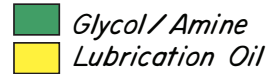

CERTIFICATIONS:

Kimray is an ISO 9001- certified manufacturer.

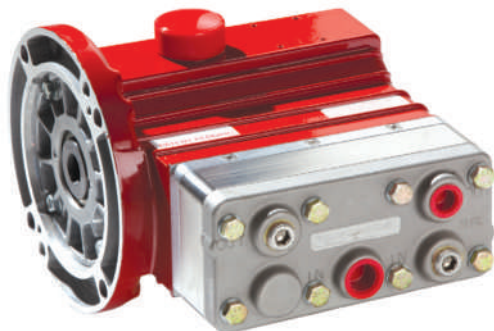

Standard Configuration Code †	Order Code	Gallons per hour Minimum	Gallons per hour Maximum ††	Operating Pressure Minimum	Operating Pressure Maximum
GEV120S	GEB	6	140	0	1200

NOTES:

† For code builder see page 10:00.3

†† Maximum output is affected by system pressure drops. See system operation parameter for maximum output curves.

ELECTRIC PUMP OVERVIEW
MODEL EV

Component Identification

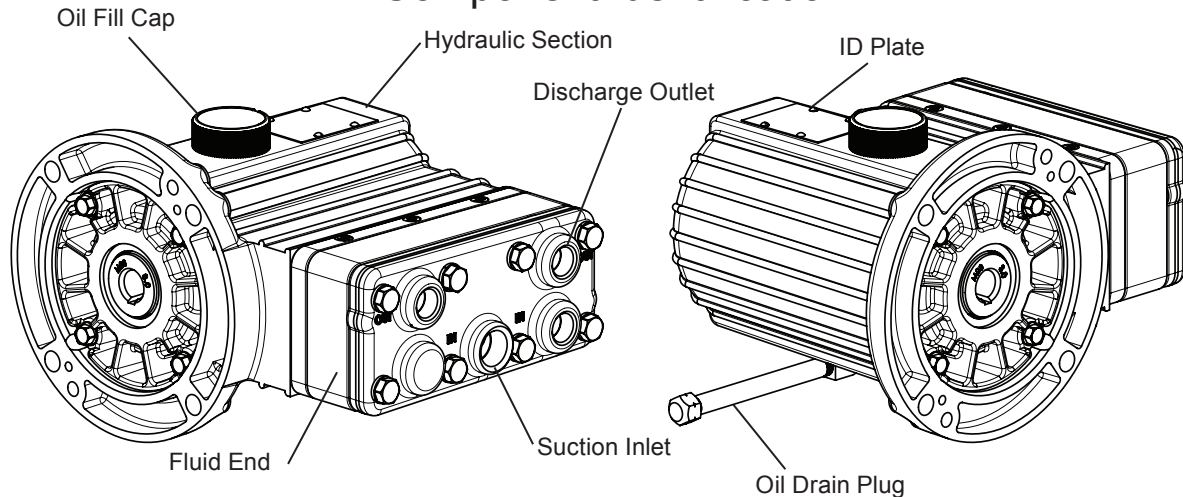

LOCATION

Locate the pump as close to the fluid supply source as possible. Allow room for checking the oil level, changing the oil (two drain plugs on the bottom and back of pump), and removing the pump head components (inlet and discharge retainer plates, manifold, and related items).

MOUNTING

The pump shaft can rotate in either direction. To prevent vibration, mount the pump and motor securely on a level rigid base. On a belt-drive system, align the sheaves accurately; poor alignment wastes horsepower and shortens the belt and bearing life. Make sure the belts are properly tightened, as specified by the belt manufacturer. On a direct-drive system, align the shafts accurately. Unless otherwise specified by the coupling manufacturer, maximum parallel misalignment should not exceed 0.015 in. (0.4 mm) and angular misalignment should be held to 1° maximum. Careful alignment extends life of the coupling, pump, shafts, and support bearings. Consult coupling manufacturer for exact alignment tolerances.

ACCESSORIES

Consult installation drawing above for typical system components. Contact KIMRAY INC. or the distributor in your area for more details.

REPAIR KITS AVAILABLE:

CAT. NO.	TYPE	MATERIAL
RZGHSN	DIAPHRAGM REPAIR KIT	HIGHLY SATURATED NITRILE
RZHHSN	CHECK VALVE REPAIR KIT	HIGHLY SATURATED NITRILE
RZHSN	COMPLETE REPAIR KIT	HIGHLY SATURATED NITRILE

OIL AVAILABLE:

CAT. NO.	TYPE	CAPACITY QUARTS	CAPACITY LITERS
7266	EGP1 KIMZOIL	1.0	1.05

IMPORTANT PRECAUTIONS

- Adequate Fluid Supply.** To avoid cavitation and premature pump failure, be sure that the pump will have an adequate fluid supply and that the inlet line will not be obstructed.
- Positive Displacement.** This is a positive-displacement pump. Install a relief valve downstream from the pump.
- Safety Guards.** Install adequate safety guards over all pulleys, belts, and couplings. Follow all codes and regulations regarding installation and operation of the pumping system.
- Shut-Off Valves.** Never install shut-off valves between the pump and discharge pressure regulator, relief valve, or in the regulator bypass line.
- Freezing Conditions.** Protect the pump from freezing. See also the Maintenance Section.
- Consult the Factory for the following situations:
 - Extreme temperature applications – above 250° F (82° C) or below 40° F (4.4° C)
 - Viscous fluid applications above 100 Cps
 - Chemical compatibility problems
 - Hot ambient temperatures – above 110° F (43° C)
 - Conditions where pump oil may exceed 200° F (93° C) because of a combination of hot ambient temperatures, hot fluid temperature, and full horsepower load — an oil cooler may be required
 - Pump RPM less than 200

CALCULATING REQUIRED HORSEPOWER (KW)*

$$\frac{6XRPM}{63,000} + \frac{GPMXPSI}{1,460} = \text{electric motor HP}^*$$

$$\frac{6XRPM}{84428} + \frac{lpm \times bar}{511} = \text{electric motor kW}^*$$

* HP/kW is required application power.

ATTENTION!

When sizing motors with variable speed drives (VFDs), it is very important to select a motor and a VFD rated for constant torque inverter duty service and that the motor is rated to meet the torque requirements of the pump throughout desired speed range.

All Pictures shown are for illustration purpose only. Actual product may vary due to product enhancement.

12012 EV Performance

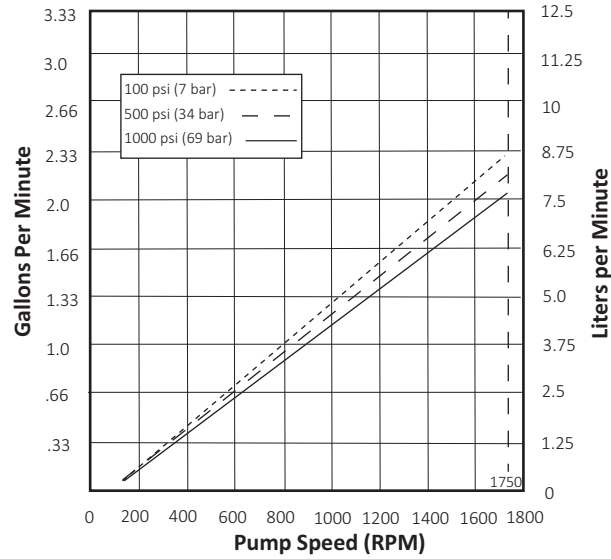

Net Positive Suction Head (NPSHr)

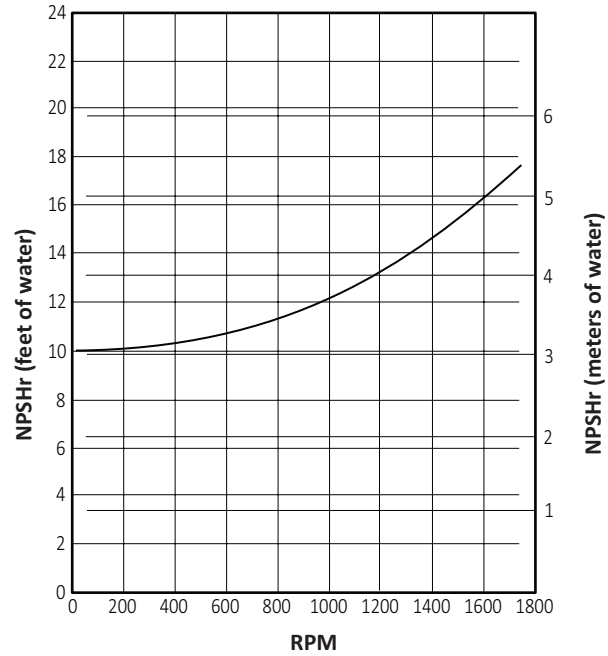

**ELECTRIC PUMP
MODEL EV - PARTS**

ITEM NO.	PART NUMBER	DESCRIPTION	QTY.	KIT
1	G10-024-2010	Cap Screw, socket-head, M10 x 1.5 x 90 mm	8	
2	D11-048-2011	Washer, flat, hardened	8	
3	G03-004-1036	Manifold, 316 SST	1	
4	D03-073-2140	O-ring, manifold, Buna	2	1,2,3
5	D25-046-2110	O-ring, valve seat, Buna	6	1,2
6	D15-020-2010	Valve Seat, 17-4 SST	6	1,2

ITEM NO.	PART NUMBER	DESCRIPTION	QTY.	KIT
7	D03-021-1015	Valve, 17-4, machined	6	1,2
8	D03-022-3114	Valve Spring, Elgiloy	6	1,2
9	D03-092-2110	Tetra Seal, Buna	6	1,2
10	D03-023-1010	Retainer, valve spring, 17-7 SST	6	1,2

Items denoted with a 1 are part of Valve Kit
 Items denoted with a 2 are part of Complete Kit
 Items denoted with a 3 are part of Diaphragm Kit

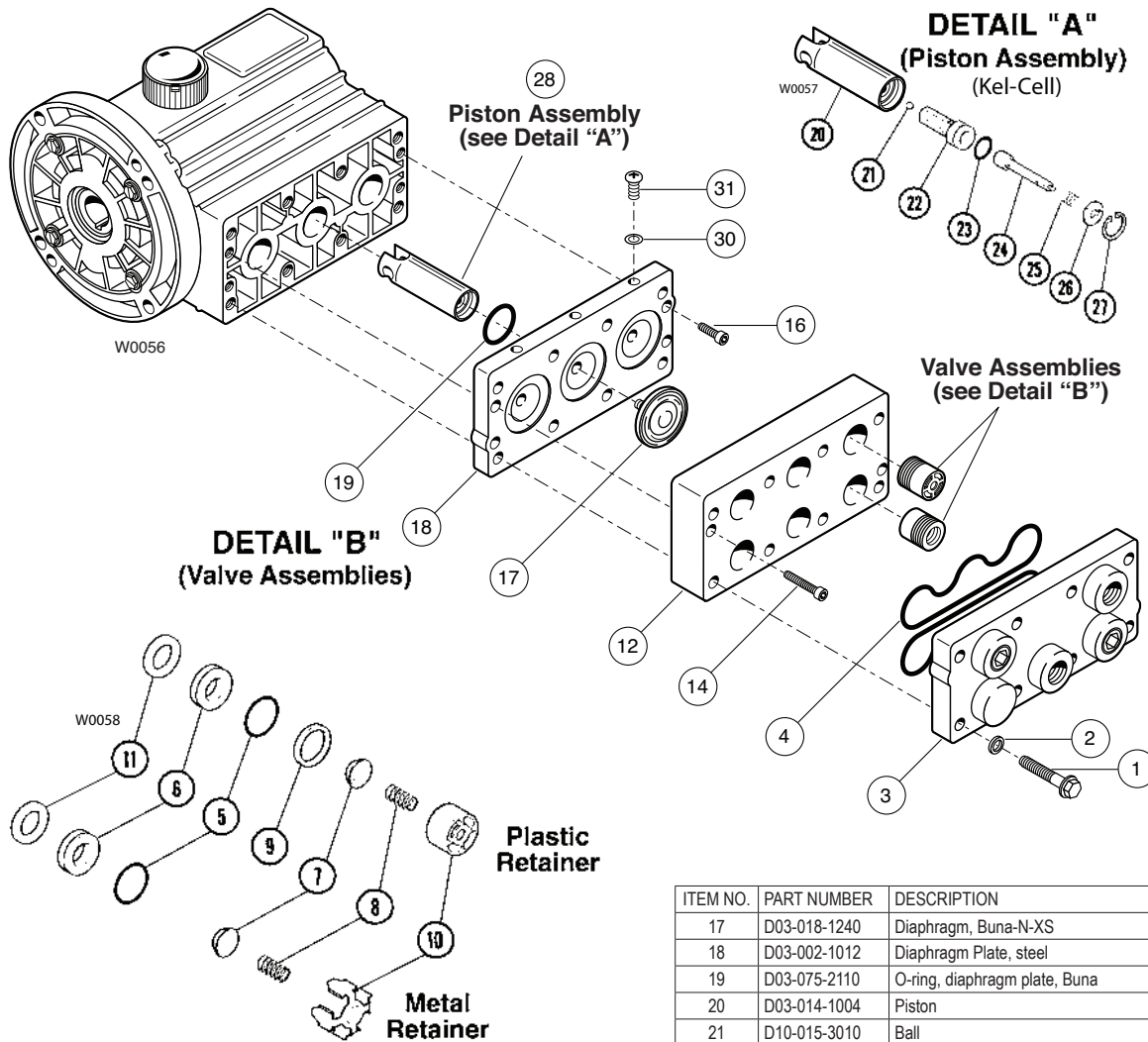

ITEM NO.	PART NUMBER	DESCRIPTION	QTY.	KIT
11	D03-125-1011	Washer, dampening, SST	6	1,2
12	D03-003-1036	Valve Plate, 316 SST	1	
14	G10-088-2010	Cap Screw, socket-head, M6 x 1.0 x 30 mm	2	
16	G03-088-2010	Cap Screw, socket-head, M6 x 1.0 x 20 mm	2	

ITEM NO.	PART NUMBER	DESCRIPTION	QTY.	KIT
17	D03-018-1240	Diaphragm, Buna-N-XS	3	2,3
18	D03-002-1012	Diaphragm Plate, steel	1	
19	D03-075-2110	O-ring, diaphragm plate, Buna	3	
20	D03-014-1004	Piston	3	
21	D10-015-3010	Ball	3	
22	D03-043-1000	Valve Cylinder	3	
23	D03-034-2110	O-ring, valve cylinder, Buna	3	
24	D03-044-1000	Valve Plunger	3	
25	D03-045-3110	Spring, sleeve valve	3	
26	D03-049-1000	Washer	3	
27	D03-048-2210	Snap Ring	3	
28	D03-014-1210	Piston Assembly	3	
29	D03-026-2210	Pin	2	

All Pictures shown are for illustration purpose only. Actual product may vary due to product enhancement.

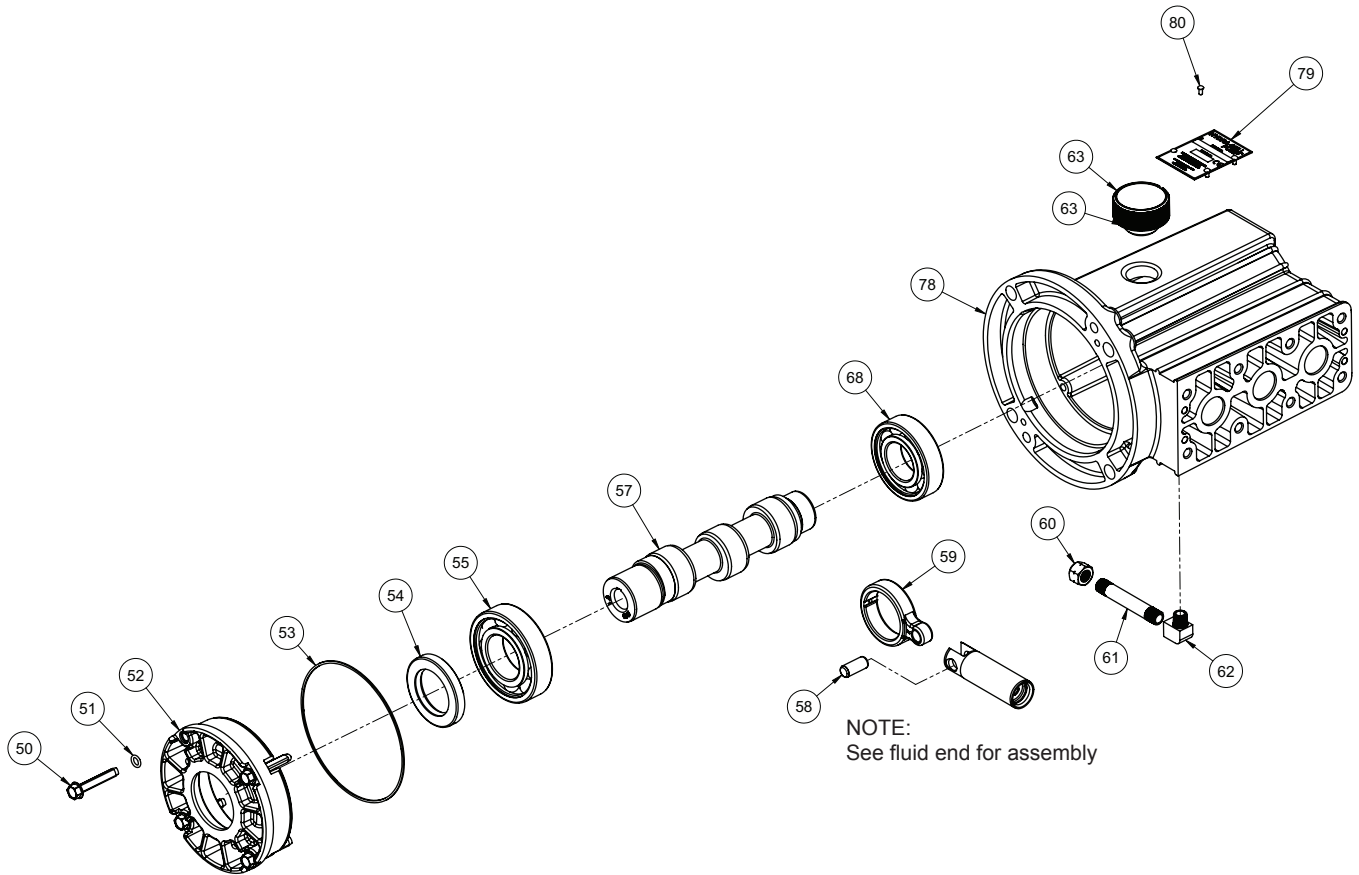

ITEM NO.	PART NUMBER	DESCRIPTION	QTY.	KIT
50	D03-086-2010	Screw, Trilobe Hex Washer Head Cap	4	
51	D25-047-21XX	O-Ring, -.010, Matrix	4	
52	D03-131-1000	Cover, Back, Die Casting	1	
53	D03-037-2110	O-Ring, -.046 Buna	1	
54	D03-031-2110	Seal, Shaft, Radial, 35mm	1	
55	D03-011-2910	Bearing, Back	1	
57	M03-009-1002	(E)Crankshaft, 2.2 Gpm	1	
58	D03-133-1000	Pin, Wrist	3	
59	D03-132-1000	Rod, Connecting	3	

ITEM NO.	PART NUMBER	DESCRIPTION	QTY.	KIT
60	D10-078-2210	Fitting, 1/8 Npt Cap Hex Brass	1	
61	D10-077-2210	Fitting, 1/8 Npt X 2.50 Lg Nipple Brass	1	
62	D10-076-2210	Fitting, 1/8 Npt Street Elbow Brass	1	
63	D03-039-1030	Assembly, Oil Cap With O-Ring	1	
68	D03-010-2910	Bearing, Front	1	
78	D03-001-1005	Pump Housing	1	
79	D10-040-2410	Name Tag	1	
80	D10-112-2200	Rivet, Name Tag	4	

Items denoted with a 1 are part of Valve Kit
 Items denoted with a 2 are part of Complete Kit
 Items denoted with a 3 are part of Diaphragm Kit

All Pictures shown are for illustration purpose only. Actual product may vary due to product enhancement.

GLYCOL PUMPS



ELECTRIC PUMP MODEL EV - DIMENSIONS

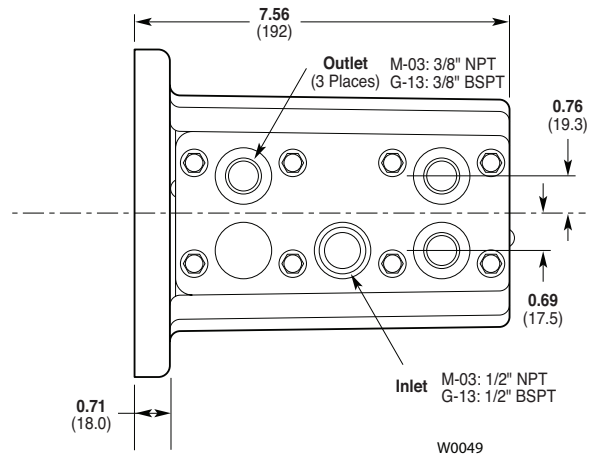
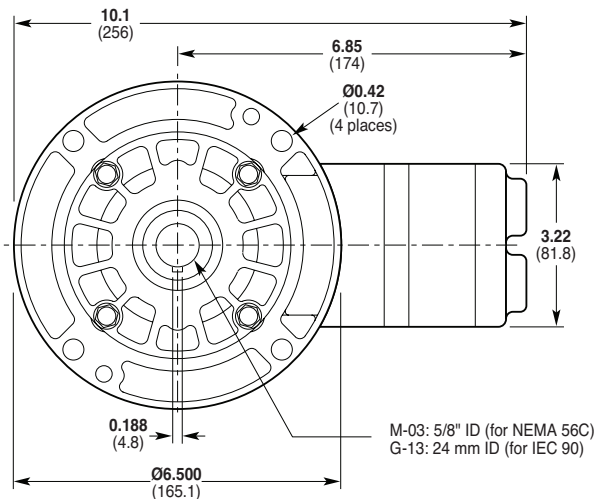

W0049

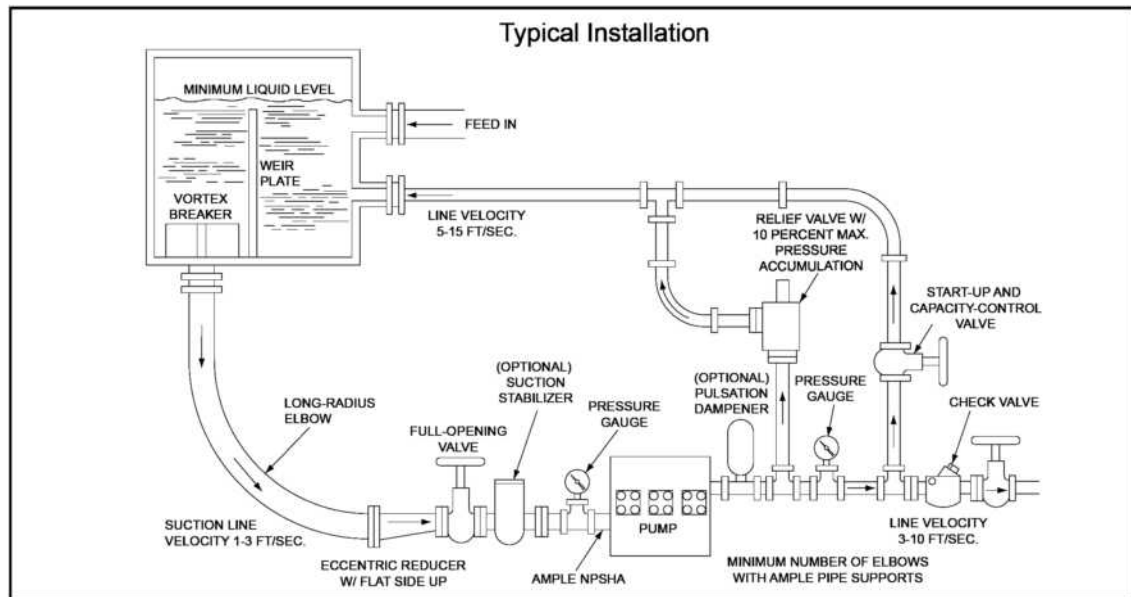

INLET PIPING (Suction Feed)

CAUTION: When pumping at temperatures above 250° F (121.1° C), use a pressure-feed system. Install drain cocks at any low points of the suction line, to permit draining in freezing conditions. Provide for permanent or temporary installation of a vacuum gauge to monitor the inlet suction. To maintain maximum flow, vacuum at the pump inlet should not exceed 7 in. Hg at 70° F (180 mm Hg at 21° C). **Do not supply more than one pump from the same inlet line if possible.**

Supply Tank

Use a supply tank that is large enough to provide time for any trapped air in the fluid to escape. The tank size should be at least twice the maximum pump flow rate. Isolate the pump and motor stand from the supply tank, and support them separately. Install a separate inlet line from the supply tank to each pump. Install the inlet and bypass lines so they empty into the supply tank below the lowest water level, on the opposite side of the baffle from the pump suction line. If a line strainer is used in the system install it in the inlet line to the supply tank. To reduce aeration and turbulence, install a completely submerged baffle plate to separate the incoming and outgoing liquids. Install a vortex breaker in the supply tank, over the outlet port to the pump. Place a cover over the supply tank, to prevent foreign objects from falling into it.

Hose and Routing

Size the suction line at least one size larger than the pump inlet, and so that the velocity will not exceed 1-3 ft/sec (0.3 to 0.9 m/s):
 For pipe in inches: Velocity (ft/sec) = 0.408 x GPM/Pipe ID2
 For pipe in mm: Velocity (m/sec) = 21.2 x LPM/Pipe ID2
 Keep the suction line as short and direct as possible. Use flexible hose and/or expansion joints to absorb vibration, expansion, or contraction. If possible, keep suction line level. Do not have any high points collecting vapor unless high points are vented. To reduce turbulence and resistance, do not use 90° elbows. If turns are necessary in the suction line, use 45° elbows or ar-range sweeping curves in the flexible inlet hose. If a block valve is used, be sure it is fully opened so that the flow

to the pump is not restricted. The opening should be at least the same diameter as the inlet plumbing ID. Do not use a line strainer or filter in the suction line unless regular maintenance is assured. If used, choose a top loading basket. It should have a free-flow area of at least three times the free-flow area of the inlet. Install piping supports where necessary to relieve strain on the inlet line and to minimize vibration.

INLET PIPING (Pressure Feed)

Provide for permanent or temporary installation of a vacuum/pressure gauge to monitor the inlet vacuum or pressure. Pressure at the pump inlet should not exceed 250 psi (17 bar); if it could get higher, install an inlet pressure reducing regulator. Do not supply more than one pump from the same inlet line.

INLET CALCULATIONS

Acceleration Head

Calculating the Acceleration Head
 Use the following formula to calculate acceleration head losses. Subtract this figure from the NPSHa, and compare the result to the NPSHr of the Hydra-Cell pump.

$$H_a = (L \times V \times N \times C) \div (K \times G)$$
 where:
 H_a = Acceleration head (ft of liquid)
 L = Actual length of suction line (ft) — not equivalent length
 V = Velocity of liquid in suction line (ft/sec) [V = GPM x (0.408 ÷ pipe ID²)]
 N = RPM of crank shaft
 C = Constant determined by type of pump — use 0.066 for the EV50015 Hydra-Cell pumps
 K = Constant to compensate for compressibility of the fluid — use: 1.4 for de-aerated or hot water; 1.5 for most liquids; 2.5 for hydrocarbons with high compressibility
 G = Gravitational constant (32.2 ft/sec²)

Friction Losses

Calculating Friction Losses in Suction Piping
 When following the above recommendations (under "Inlet Piping") for minimum hose/pipe I. D. and maximum length, frictional losses in the suction piping are negligible (i.e., H_f = 0) if you are pumping a water-like fluid. When pumping more-viscous fluids such as lubricating oils, sealants, adhesives, syrups, varnishes, etc., frictional losses in the

ELECTRIC PUMP

MODEL EV - INSTALLATION

suction piping may become significant. As Hf increases, the available NPSH (NPSHa) will decrease, and cavitation will occur. In general, frictional losses increase with increasing viscosity, increasing suction-line length, increasing pump flow rate, and decreasing suction-line diameter. Changes in suction-line diameter have the greatest impact on frictional losses: a 25% increase in suction-line diameter cuts losses by more than two times, and a 50% increase cuts losses by a factor of five times. Consult the factory before pumping viscous fluids.

Minimizing Acceleration Head and Frictional Losses

To minimize the acceleration head and frictional losses:

- Keep inlet lines less than 6 ft (1.8 m) or as short as possible
- Use at least 1-1/2 in. (38.1 mm) I.D. inlet hose
- Use suction hose (low-pressure hose, non collapsing) for the inlet lines
- Minimize fittings (elbows, valves, tees, etc.)
- **Use a suction stabilizer on the inlet.**

Net Positive Suction Head

NPSHa must be equal to or greater than NPSHr. If not, the pressure in the pump inlet will be lower than the vapor pressure of the fluid — and cavitation will occur.

Calculating the NPSHa

Use the following formula to calculate the NPSHa:

$$NPSHa = P_t + H_z - H_f - H_a - P_{vp}$$

where:

P_t = Atmospheric pressure

H_z = Vertical distance from surface liquid to pump center line
(if liquid is below pump center line, the H_z is negative)

H_f = Friction losses in suction piping

H_a = Acceleration head at pump suction

P_{vp} = Absolute vapor pressure of liquid at pumping temperature

NOTES:

- In good practice, NPSHa should be 2 ft greater than NPSHr
- All values must be expressed in feet of liquid

Atmospheric Pressure at Various Altitudes

Altitude (ft)	Pressure (ft of H ₂ O)	Altitude (ft)	Pressure (ft of H ₂ O)
0	33.9	1500	32.1
500	33.3	2000	31.5
1000	32.8	5000	28.2

DISCHARGE PIPING

Hose and Routing

Use the shortest, most-direct route for the discharge line.

Select pipe or hose with a working pressure rating of at least 1.5 times the maximum system pressure. EXAMPLE: Select a 1500 psi W.P.-rated hose for systems to be operated at 1000 psi-gauge pressure.

Use flexible hose between the pump and rigid piping to absorb vibration, expansion or contraction.

Support the pump and piping independently. Size the discharge line so that the velocity of the fluid will not exceed 7-10 ft/sec (2-3 m/sec):

For pipe in inches: Velocity (ft/sec) = 0.408 x GPM/Pipe ID²

For pipe in mm: Velocity (m/sec) = 21.2 x LPM/Pipe ID²

Pressure Relief

Install a pressure relief valve in the discharge line. Bypass pressure must not exceed the pressure limit of the pump.

Size the relief valve so that, when fully open, it will be large enough to relieve the full capacity of the pump without overpressurizing the system.

Locate the valve as close to the pump as possible and ahead of any other valves.

Adjust the pressure relief valve to no more than 10% over the

maximum working pressure of the system. Do not exceed the manufacturer's pressure rating for the pump or relief valve.

Route the bypass line to the supply tank. See the diagram showing a typical installation at the beginning of the Installation Section.

If the pump may be run for a long time with the discharge closed and fluid bypassing, install a thermal protector in the bypass line (to prevent severe temperature buildup in the bypassed fluid).

CAUTION: Never install shutoff valves in the bypass line or between the pump and pressure relief valve.

Install a pressure gauge in the discharge line.

BEFORE INITIAL START-UP

Before you start the pump, be sure that:

- Pump is stored at a temperature between 40-180 F (4.4-82.2 C) for a minimum of 24 hours before start up.
- All shutoff valves are open, and the pump has an adequate supply of fluid.
- All connections are tight.
- The oil level is within the marking on the dipstick. Add oil as needed.
- The relief valve on the pump outlet is adjusted so the pump starts under minimum pressure.
- All shaft couplings or drive pulleys have adequate safety guards.

INITIAL START-UP

1. Pump must be at or above 40 F (4.4 C) for 24 hours prior to starting.
2. Open the bypass line start-up and capacity-control valve so the pump may be started against negligible discharge pressure.
3. Turn on power to the pump motor.
4. Check the inlet pressure or vacuum. To maintain maximum flow, inlet vacuum must not exceed 7 in. Hg at 70° F (180 mm Hg at 21° C). Inlet pressure must not exceed 250 psi (17 bar).
5. Listen for any erratic noise, and look for unsteady flow. If the pump does not clear, refer to the Troubleshooting Section.
6. If the system has an air lock and the pump fails to prime:
 - a. Turn off the power.
 - b. Remove the pressure gauge from the tee fitting at the pump outlet (see installation diagram).
NOTE: Fluid may come out of this port when the plug is removed. Provide an adequate catch basin for fluid spillage, if required. Fluid will come out of this port when the pump is started, so we recommend that you attach adequate plumbing from this port so fluid will not be sprayed or lost. Use high-pressure-rated hose and fittings from this port. Take all safety precautions to assure safe handling of the fluid being pumped.
 - c. Jog the system on and off until the fluid coming from this port is air-free.
 - d. Turn off the power.
 - e. Remove the plumbing that was temporarily installed, and reinstall the pressure gauge or plug.
7. Adjust the bypass line valve to the desired operating pressure. Do not exceed the maximum pressure rating of the pump.
8. After the system pressure is adjusted, verify the safety relief valve setting by closing the bypass line valve until the relief valve opens.

NOTE: Fluid may come out of the safety relief valve. Provide an adequate catch basin for fluid spillage. Take all safety precautions to assure safe handling of the spillage.

9. Reset the bypass line valve to obtain the desired system pressure.
10. Provide a return line from the relief valve to the supply tank, similar to the bypass line.

NOTE: The numbers in parentheses are the Reference Numbers on the exploded view illustrations found in this manual and in the Parts Manual.

DAILY

Check the oil level and the condition of the oil with the pump turned off. The oil level should be within the marking on the dipstick. Add oil as needed. Use KIMZOIL EGP1 Electric Glycol Pump Oil (Kimray part no. 6928) for the application.

CAUTION: If you are losing oil but don't see any external leakage, or if the oil becomes discolored and contaminated, one of the diaphragms (41) may be damaged. Refer to the Fluid-End Service Section. Do not operate the pump with a damaged diaphragm.

CAUTION: Do not leave contaminated oil in the pump housing or leave the housing empty. Remove contaminated oil as soon as discovered, and replace it with clean oil.

PERIODICALLY

Change the oil after the first 500 hours of operation, and then according to the guidelines below.

Hours Between Oil Changes @ Various
Process Fluid Temperatures

Pressure	RPM	<150°F (32°C)	<200°F (60°C)	<250°F (82°C)
<1000 psi (69 bar)	<800	6,000	4,500	3,000
	<1200	4,000	3,000	2,000
<1500 psi (100 bar)	<800	4,000	3,000	2,000
	<1200	2,000	1,500	1,000

NOTE: Minimum oil viscosity for proper hydraulic end lubrication is 16-20 cST (80-100 SSU) at 212°F (100°C).

NOTE: Use of an oil cooler is recommended when process fluid and/or hydraulic end oil exceeds 200°F (93°C).

When changing oil, remove both drain plugs (13) at the bottom of the pump so all oil and accumulated sediment will drain out.

CAUTION: Do not turn the drive shaft while the oil reservoir is empty.

Check the inlet pressure or vacuum periodically with a gauge. If vacuum at the pump inlet exceeds 7 in. Hg (180 mm Hg), check the inlet piping system for blockages. If the pump inlet is located above the supply tank, check the fluid supply level and replenish if too low.

CAUTION: Protect the pump from freezing. Refer also to the "Shutdown Procedure".

SHUTDOWN PROCEDURE DURING FREEZING TEMPERATURES

Take all safety precautions to assure safe handling of the fluid being pumped. Provide adequate catch basins for fluid drainage and use appropriate plumbing from drain ports, etc., when flushing the pump and system with a compatible anti-freeze.

PUMP STORAGE

CAUTION: If the pump is to be stored more than six months take the following steps to protect against corrosion:

1. Change crankcase oil.
2. Change oil behind diaphragms.
3. Remove suction and discharge valves and drain pump of all liquids. Use compressed air to dry inside passageways of manifold.
4. Apply light film of clean oil or corrosion inhibitor to all inside passageways of manifold.
5. Clean and dry valves and seats. Apply light film of clean oil or corrosion inhibitor to valves and seats.
6. Reinstall valves with new o-rings.
7. Plug suction and discharge ports to protect against dirt and moisture.
8. Store pump in clean and dry location.
9. Every month of storage rotate crankshaft 4 to 6 times.

ELECTRIC PUMP

MODEL EV - TROUBLESHOOTING

CAVITATION

- Inadequate fluid supply because:
 - Inlet line collapsed or clogged
 - Clogged line strainer
 - Inlet line too small or too long
 - Air leak in inlet line
 - Worn or damaged inlet hose
 - Suction line too long
 - Too many valves and elbows in inlet line
- Fluid too hot for inlet suction piping system
- Air entrained in fluid piping system
- Aeration and turbulence in supply tank
- Inlet vacuum too high (refer to "Inlet Calculations" paragraph)

Symptoms of Cavitation

- Excessive pump valve noise
- Premature failure of spring or retainer
- Volume or pressure drop
- Rough-running pump
- Premature failure

DROP IN VOLUME OR PRESSURE

A drop in volume or pressure can be caused by one or more of the following:

- Air leak in suction piping
- Clogged suction line or suction strainer
- Suction line inlet above fluid level in tank
- Inadequate fluid supply
- Pump not operating at proper RPM
- Relief valve bypassing fluid
- Worn pump valve parts
- Foreign material in inlet or outlet valves
- Loss of oil prime in cells because of low oil level
- Ruptured diaphragm
- Cavitation
- Warped manifold from overpressurized system
- O-rings forced out of their grooves from overpressurization
- Air leak in suction line strainer or gasket
- Cracked suction hose
- Empty supply tank
- Excessive aeration and turbulence in supply tank
- Worn and slipping drive belt(s)
- Worn spray nozzle(s)
- Cracked cylinder

PUMP RUNS ROUGH

- Worn pump valves
- Air lock in outlet system
- Oil level low
- Wrong weight of oil for cold operating temperatures (change to lighter weight)
- Cavitation
- Air in suction line
- Restriction in inlet/suction line
- Hydraulic cells not primed after changing diaphragm
- Foreign material in inlet or outlet valve
- Damaged diaphragm
- Fatigued or broken valve spring

PREMATURE FAILURE OF DIAPHRAGM

- Frozen pump
- Puncture by a foreign object
- Elastomer incompatible with fluid being pumped
- Pump running too fast
- Excess pressure
- Cavitation
- Aeration or turbulence in supply tank

VALVE WEAR

- Normal wear from high-speed operation
- Cavitation
- Abrasives in the fluid
- Valve incompatible with corrosives in the fluid
- Pump running too fast

LOSS OF OIL

- External seepage
- Rupture of diaphragm
- Frozen pump
- Worn shaft seal
- Oil drain plug or fill cap loose
- Valve plate and manifold bolts loose

PREMATURE FAILURE OF VALVE SPRING OR RETAINER

- Cavitation
- Foreign object in the pump
- Pump running too fast
- Spring/retainer material incompatible with fluid being pumped
- Excessive inlet pressure

FLOAT SWITCH

FUNCTION / PURPOSE:

The FLOAT SWITCH is installed in the rear cover of the pump and is used to detect HIGH or LOW oil level in the crank case.

INSTALLATION DESCRIPTION

Install by removing the adapter and conduit plug from the pump rear cover, secure the switch into the adapter and reinstall the assembly into the rear cover.

PART NUMBER	DESCRIPTION
6926	500EV FLOAT SWITCH ASSY

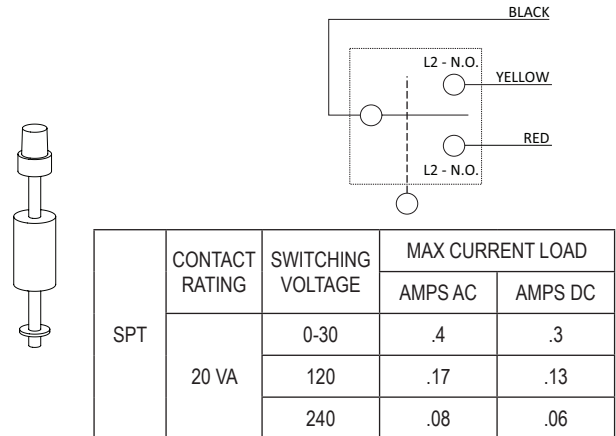

SHAFT COUPLINGS

FUNCTION / PURPOSE:

The SHAFT COUPLINGS join the motor and pump shafts with an elastomeric cushion. A properly sized coupling is required for each shaft. Additionally, a spider cushion installs between the two couplings.

PART NUMBER	DESCRIPTION
6902	BUNA COUPLING SPIDER
6900	Ø 1.000" BORE COUPLING
6917	Ø 1.375" BORE COUPLING
6901	Ø 1.625" BORE COUPLING

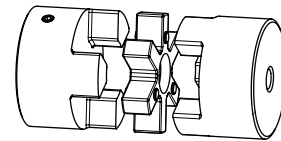

C-FACE MOTOR ADAPTER

FUNCTION / PURPOSE:

The MOTOR ADAPTER rigidly connects and aligns the pump and motor together for direct-drive applications. The adapter also serves as a protective guard around the spinning shafts.

PART NUMBER	DESCRIPTION	NEMA FRAME SIZE
GKF	50015 EV MOTOR ADAPTER KIT	213T / 215T
GKG	50015 EV MOTOR ADAPTER KIT	254T / 256T

INCLUDES MOUNTING HARDWARE

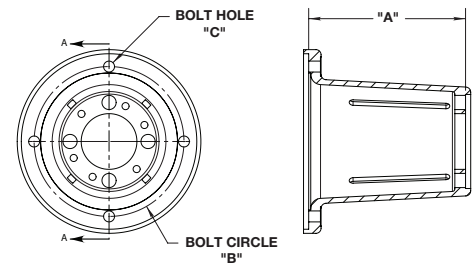

FRAME SIZE	A	B	C
213T/215T	6.100"	7.250"Ø	.531"Ø
254T/256T	7.600"	7.250"Ø	.531"Ø

SKID

PART NUMBER	DESCRIPTION	NEMA FRAME SIZE
GKH	50015 EV SKID KIT	213T / 215T
GKI	50015 EV SKID KIT	254T / 256T

INCLUDES MOUNTING HARDWARE

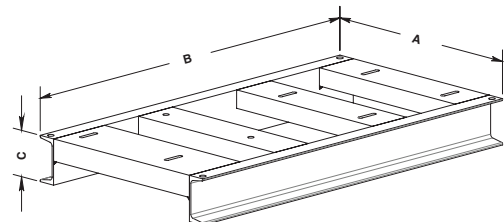

FRAME SIZE	A	B	C
213T/215T	19 11/64"	29 1/2"	4"
254T/256T	19 5/32"	35 5/16"	4"

NOTES:



Kimray is an ISO 9001- certified manufacturer.