



BALANCED MOTOR VALVES

Models MA DB PO, MA DB PC, MA PB PO, MA PB PC

Instruction Manual: IME3MA



MA DB PO, MA PB PO
Cast Iron, Ductile Iron,
& Steel
Normally Closed



MA DB PC, MA PB PC
Cast Iron, Ductile Iron,
& Steel
Normally Open

DESCRIPTION:

The Balanced Motor Valves, Model MA DB and MA PB are designed for use in liquid dump control applications which require on/off service. The valves have a single port body and a pneumatic spring/diaphragm actuator. Because the word motor is defined as "that which imparts motion", the term "motor valve" is used considering the diaphragm actuator to be the "motor".

The actuator is available in either Pressure Opening, (normally closed) or Pressure Closing (normally open) configurations. Valve model designations indicate PO for Pressure Opening or PC for pressure closing actuators.

The Model MA **DB** is balanced by a diaphragm and is recommended for service pressure of no more than 125 psig (8.6 bar). The letters "DB" in the model name designate "Diaphragm Balanced".

The Model MA **PB** is balanced by a piston and its maximum operating pressure is limited only by the pressure rating of the body. The letters "PB" in the model name designate "Piston Balanced".

Because of the nominal pressure range, a single O-Ring seal with back ups provides the packing for the stem.

The Model MA DB and MA PB are diaphragm operated control valves featuring quick-opening trim for on/off service. The valve is balanced allowing it to function smoothly and close completely regardless of the pressure differential from upstream to downstream. The valve's large opening provides high flowing capacity. No more than 10 psig (0.7 bar) instrument gas pressure is required to fully operate the valve.

A name tag is attached to the actuator housing on each valve. The name tag lists the serial number, model number, and pressure rating. An additional tag is installed to indicate any special trim options, should they be required.

When servicing valves, always use only Kimray replacement parts. For specific model numbers, part numbers, and repair kit numbers, refer to the Kimray Catalog, Section E3, or to the packing slip which is enclosed with each valve.

AVAILABLE MODELS

Connection Size: 2", 3", 4"

Connection Style: NPT or Flanged

Body Style: Angle or Thru

Actuation: Pressure Opening or Pressure Closing

Body Material: Cast Iron, Ductile Iron, Steel

SPECIFICATIONS

Normal Service: Liquids

Features:

- Designed for on / off service
- Shut off at full rated upstream pressure
- Large size port for high capacity
- Balanced single seat
- 10 psi (0.7 bar) minimum required diaphragm pressure
- Up to 100 psi (6.7 bar) max. allowable diaphragm pressure
- Soft seat for bubble tight shut-off
- Available in Pressure Opening or Pressure Closing
- Available in Angle or Thru Body

Construction Materials:

BODY	CAST IRON	DUCTILE IRON	STEEL
STEM	303 Stainless	303 Stainless	303 Stainless
PLUG	Ductile Iron	Ductile Iron	Steel
PISTON	303 Stainless	303 Stainless	303 Stainless
CYLINDER	303 Stainless	303 Stainless	303 Stainless
SEAT	Nitrile	Polyurethane	Polyurethane
DIAPHRAGM	Nitrile/Nylon	Nitrile/Nylon	Nitrile/Nylon



BALANCED MOTOR VALVES

Models MA DB PO, MA DB PC, MA PB PO, MA PB PC

SPECIFICATIONS - Continued

Body End Connections & Pressure Ratings:

Body Pressure Rating

Cast Iron:	2", 3", 4" NPT	175 psig (12 bar)
	2", 3", 4" ANSI 125 Flanged	175 psig (12 bar)
Ductile Iron:	2" NPT	500 psig (34.5 bar)
	3" & 4" NPT	300 psig (20.7 bar)
	2", 3", 4" ANSI 150 RF Flanged ...	250 psig (17.2 bar)
Steel:	2", 3", 4" ANSI 150 RF Flanged ...	285 psig (19.6 bar)

Max. Recommended Operating Pressure:

Model MA DB: 125 psig (8.6 bar)

Model MA PB: Same as Body Pressure Rating (listed above)

Normal Operating Temperature:

-20° to 200° F

-29° to 93° C

Options:

Elastomers: HSN, Viton®, Aflas®

Trim Material: 316 Stainless Steel internal parts

Installation:

Normally with actuator in vertical orientation.

INSTALLATION:

BEFORE INSTALLATION:

Be sure you fully understand the application, operation, and connection of the device before installing.

WARNING:

Only trained personnel should install or service a control valve. Control valves and other control devices should be installed, operated, and maintained in accordance with international codes and regulations, manufacturer's instructions, and proven best practices.

Personal injury, equipment damage, property damage, leakage or bursting of pressure-containing parts may result if the valve is overpressured or installed where service conditions could exceed the limits given in the SPECIFICATIONS section.

Overpressure protection should also be provided if the valve inlet pressure may exceed the safe working pressure of the equipment downstream.

To avoid injury or damage, install pressure-relieving or pressure limiting devices to prevent service conditions from exceeding those limits. Consult the appropriate code, regulations, or standards.

Consideration should be given to the potential risk of injury or property damage due to escaping fluid. To avoid such risks, install the regulator in a safe location.

Inspect the openings in the valve for foreign material and clean the pipe lines to remove scale, chips, and debris.

Install the valve with the arrow on the body pointing in the direction of flow. The arrow signifies that the device will operate properly in the direction of flow indicated and will not necessarily prevent flow in the opposite direction. **If conditions indicate the possibility of backward flow you may wish to install check valves.**

A person should never stand directly over or in front of a valve when the system is pressurized. Never look directly into a valve in a pressurized system. The valve could suddenly open, blowing gas, dirt, metal particles, or other debris into the person's face and eyes.

Install the valve using good piping practice. For flanged bodies use a suitable gasket between the body and the pipeline flanges. For threaded (NPT) bodies, use TFE tape or pipe thread sealant on external pipe threads.

The flanged valve bodies are rated ANSI class 125 or 150. Do not install the valve in a system where the working pressure can exceed ANSI class ratings.

Connect instrument gas (usually from a liquid level control pilot) to the actuator connection. The minimum required instrument gas pressure is 10 psig (0.7 bar); up to 100 psig (6.7 bar) is permissible.

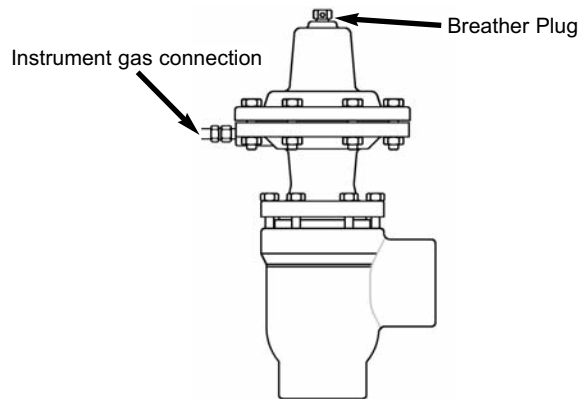

Pressure Closing Valve

Pressure Closing Valve: Remove the plastic stopper from the tapped hole in the lip of the housing immediately below the bonnet and install a tubing fitting (not provided). 1/4" or 3/8" tubing (not provided) must be installed from your source of instrument gas. The fitting at the top of the bonnet is a breather plug.

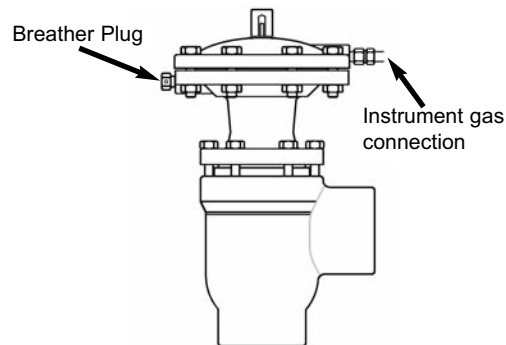

Pressure Opening Valve

Pressure Opening Valve: Remove the plastic stopper from the tapped hole in the lip of the bonnet and install a tubing fitting (not provided). 1/4" or 3/8" tubing (not provided) must be installed from your source of instrument gas. The fitting in the lip of the housing immediately below the bonnet is a breather plug.



BALANCED MOTOR VALVES

Models MA DB PO, MA DB PC, MA PB PO, MA PB PC

START-UP & TEST:

With installation completed and appropriate relief and check valves installed and set, slowly open the upstream and downstream shutoff valves. In order to test the function of the valve allow only a small amount of upstream fluid to flow through the upstream shutoff valve. Check for proper valve operation by cycling the actuator several times.

WARNING:

Before performing any service be sure that the valve is fully isolated and that all pressure upstream and downstream has been relieved. Use bypass valves or fully shut off the process.

Be sure that any operating or instrument gas lines have been disconnected.

Never assume that a check valve is fully blocking the downstream line.

Never tighten any fitting or the main connections to the valve while there is pressure on the line.

NOTE:

When a gasket seal is disturbed during disassembly a new gasket should be installed during reassembly to ensure proper sealing.

MAINTENANCE:

Maintenance should be performed on a regular basis. An initial inspection interval of 12 months is recommended. Depending on the service conditions and the condition of the valve, the inspection interval may be decreased or increased.

Warning: If the valve leaks fluid, it indicates that service is required. Failure to take the valve out of service immediately may create a hazardous condition.

The valve can be repaired without being removed from the piping.

Detailed repair instructions are available for your specific valve.

Repair Kits are available. Consult the Kimray Catalog, Section E3, or the packing slip which is enclosed with each valve for the correct Repair Kit number.

REPAIR HINTS:

- Make sure there is minimum "play" of valve stem in the stem guide located in the upper end of the cylinder.
- Evenly tighten the screws which hold the middle housing to the valve body.
- Diaphragms will harden with age.

TROUBLE SHOOTING:

SYMPTOM	POSSIBLE CAUSE
Fluid leaking from actuator	Stem packing or the stem itself is worn.
Fluid leaking from body/actuator joint.	Screws attaching actuator to body are loose. Gasket between body and actuator is worn or damaged.
Valve will not cycle when instrument air is applied to actuator.	Diaphragm is ruptured or torn. Valve stem is broken. Diaphragm plate is loose. Actuator vent is plugged.
Excessive trim leakage with the valve closed.	Debris is interfering with seat contact. Insufficient shut-off force from actuator. Seat surfaces are worn or damaged.
Instrument gas leaks from outer edge of diaphragm housing.	Screws holding the bonnet to the middle housing are loose.
Instrument gas leaks from actuator vent.	Diaphragm is torn or ruptured.
Valve stem movement is sticky or jerks.	Valve stem is bent or misaligned.

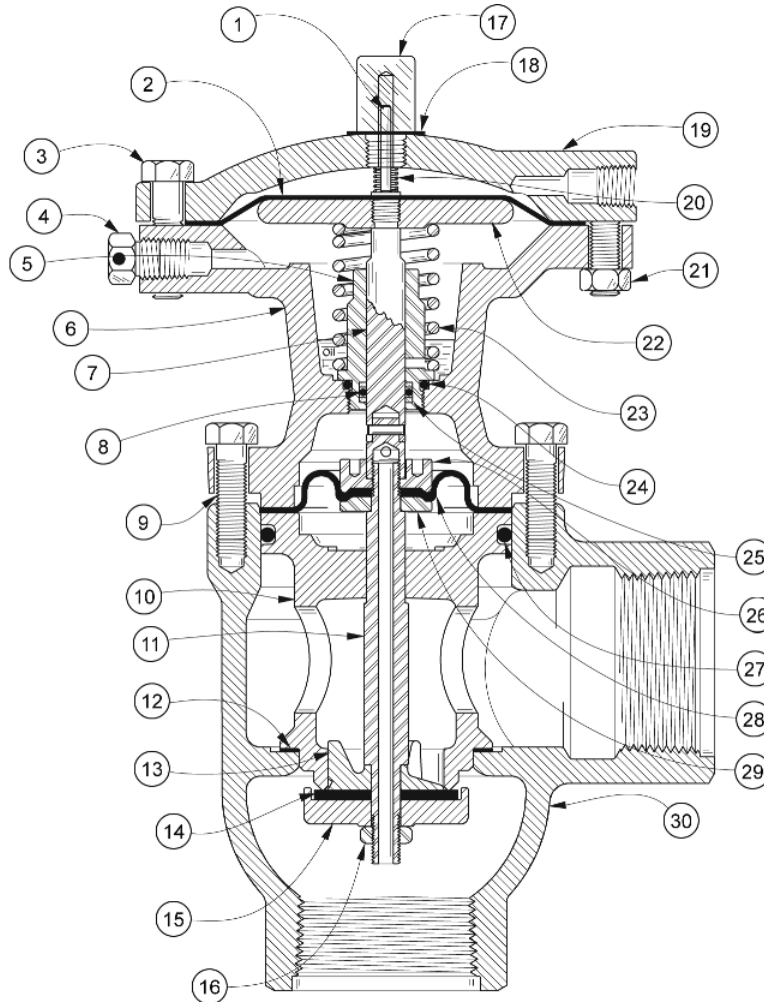

This is a general representation of a Diaphragm Balanced Motor Valve model MA DB PO.

For specific parts and their orientation refer to the Kimray Catalog or the packing slip which is enclosed with each regulator.

Key Description

- 1 Travel Indicator Stem, aluminum
- 2 Diaphragm, nylon reinforced nitrile
- 3 Screw, plated steel
- 4 Breather Plug, aluminum
- 5 Stem Guide, plated steel
- 6 Housing, cast iron or ductile iron
- 7 Stem Assembly, stainless steel
- 8 O-Ring, nitrile
- 9 Screw, plated steel
- 10 Cage, ductile iron

Key Description

- 11 Stem, stainless steel
- 12 Gasket
- 13 Ratio Plug, ductile iron
- 14 Seat, *nitrile or **polyurethane
- 15 Seat disc, ductile iron
- 16 Lock Nut, plated steel
- 17 Travel Indicator Housing, acetal
- 18 Gasket
- 19 Bonnet, cast iron or ductile iron
- 20 Spring

Key Description

- 21 Nut, plated steel
- 22 Diaphragm Plate, ductile iron
- 23 Spring
- 24 O-Ring, nitrile
- 25 Back Up, TFE
- 26 Diaphragm Nut, stainless steel
- 27 O-Ring, nitrile
- 28 Diaphragm, nylon reinforced nitrile
- 29 Plate, stainless steel
- 30 Body, cast iron or ductile iron

*Cast Iron Valves

**Ductile Iron & Steel Valves

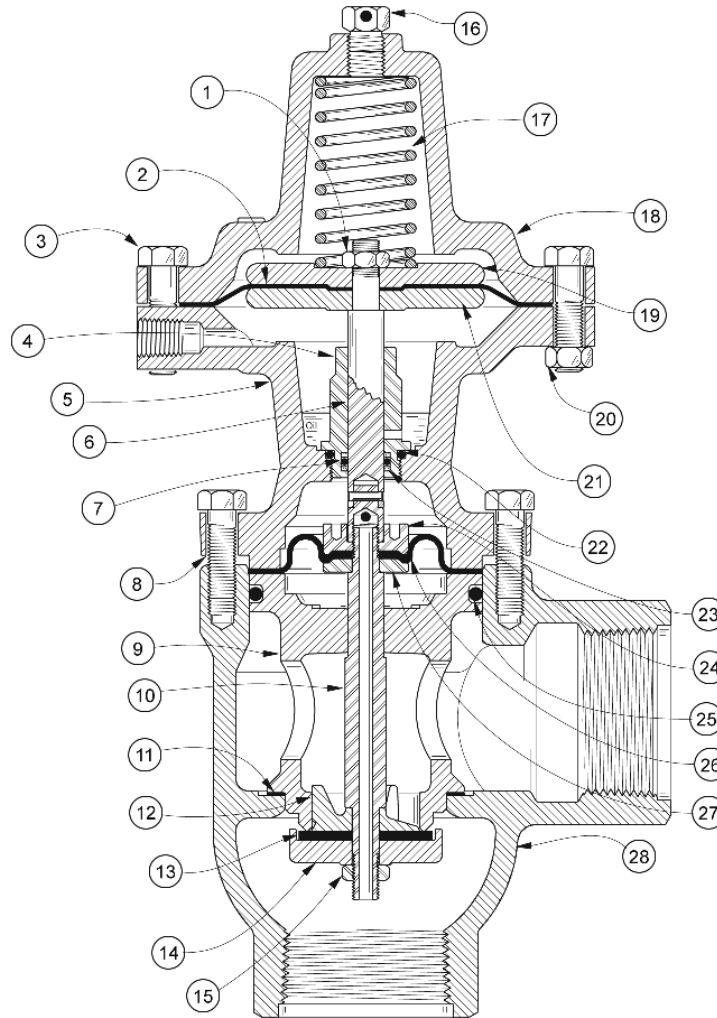

This is a general representation of a Diaphragm Balanced Motor Valve model MA DB PC.

For specific parts and their orientation refer to the Kimray Catalog or the packing slip which is enclosed with each regulator.

Key Description

- 1 Nut-2" valve, plated steel
Screw-3" & 4" valve, plated steel
- 2 Diaphragm, nylon reinforced nitrile
- 3 Screw, plated steel
- 4 Stem Guide, plated steel
- 5 Housing, cast iron or ductile iron
- 6 Stem Assembly, stainless steel
- 7 O-Ring, nitrile
- 8 Screw, plated steel
- 9 Cage, ductile iron

Key Description

- 10 Stem, stainless steel
- 11 Gasket
- 12 Ratio Plug, ductile iron
- 13 Seat, *nitrile or **polyurethane
- 14 Seat Disc, ductile iron
- 15 Lock Nut, plated steel
- 16 Breather Plug, aluminum
- 17 Spring
- 18 Bonnet, cast iron or ductile iron
- 19 Upper Plate, ductile iron

Key Description

- 20 Nut, plated steel
- 21 Lower Plate, ductile iron
- 22 O-Ring, nitrile
- 23 Back Up, TFE
- 24 Diaphragm Nut, stainless steel
- 25 O-Ring, nitrile
- 26 Diaphragm, nylon reinforced nitrile
- 27 Plate, stainless steel
- 28 Body, cast iron or ductile iron

*Cast Iron Valves

**Ductile Iron & Steel Valves

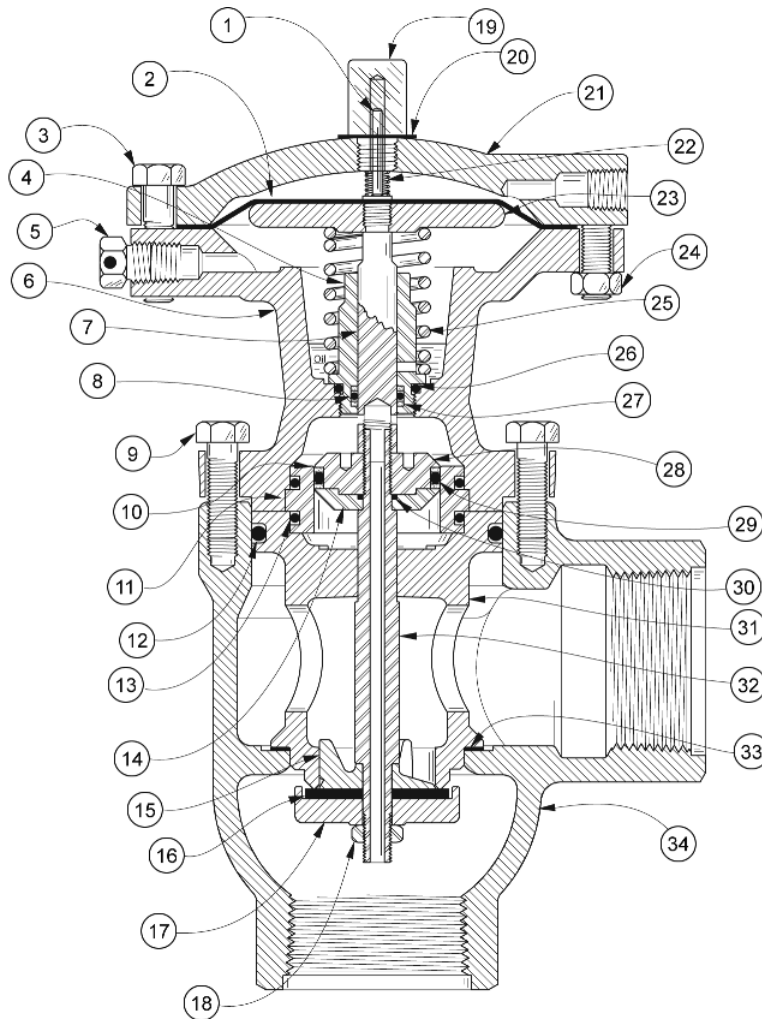

This is a general representation of a Piston Balanced Motor Valve model MA PB PO.
 For specific parts and their orientation refer to the Kimray Catalog or the packing slip which is enclosed with each regulator.

Key Description

- 1 Travel Indicator Stem, aluminum
- 2 Diaphragm, nylon reinforced nitrile
- 3 Screw, plated steel
- 4 Stem Guide, plated steel
- 5 Breather Plug, aluminum
- 6 Housing, cast iron, ductile iron, or steel
- 7 Stem, stainless steel
- 8 O-Ring, nitrile
- 9 Screw, plated steel
- 10 Back Up, TFE
- 11 Cylinder, stainless steel
- 12 O-Ring, nitrile

Key Description

- 13 O-Ring, nitrile
- 14 Piston Seal Retainer, stainless steel
- 15 Ratio Plug, ductile iron
- 16 Seat, *nitrile or **polyurethane
- 17 Seat Disc, ductile iron
- 18 Lock Nut, plated steel
- 19 Travel Indicator Housing, acetal
- 20 Gasket
- 21 Bonnet, cast iron, ductile iron, or steel
- 22 Spring
- 23 Diaphragm Plate, ductile iron or steel
- 24 Nut, plated steel

Key Description

- 25 Spring
- 26 O-Ring
- 27 Back Up, TFE
- 28 Piston, stainless steel
- 29 O-Ring, nitrile
- 30 O-Ring, nitrile
- 31 Cage, ductile iron
Removable Seat, **stainless steel
- 32 Stem, stainless steel
- 33 Gasket
- 34 Body, cast iron, ductile iron, or steel

*Cast Iron Valves

**Ductile Iron & Steel Valves

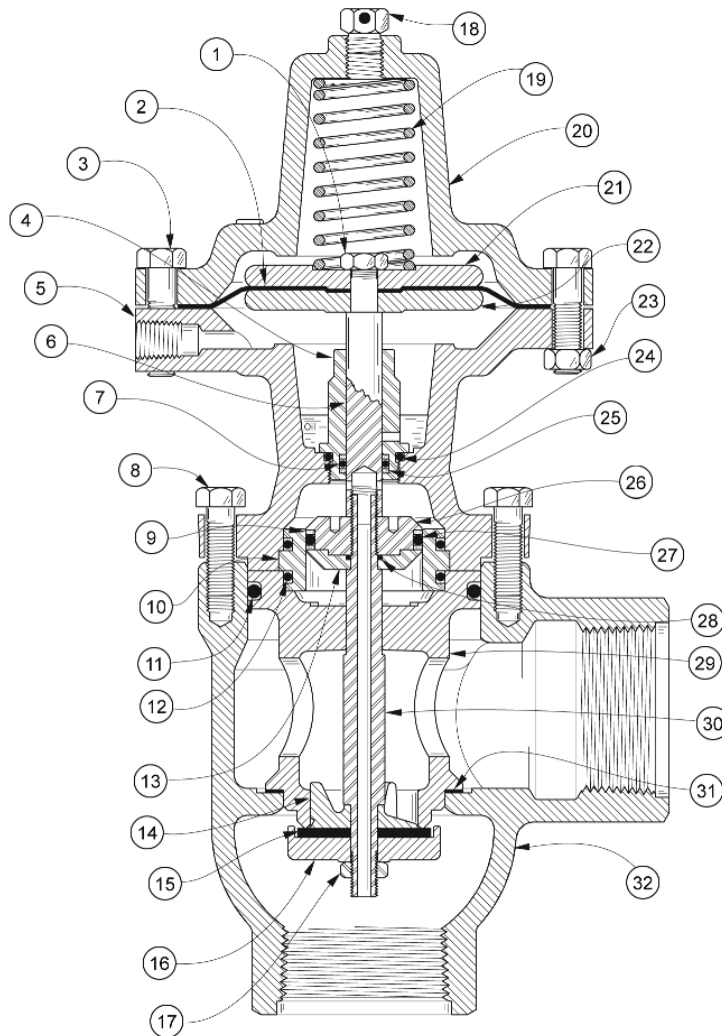

This is a general representation of a Piston Balanced Motor Valve model MA PB PC.
 For specific parts and their orientation refer to the Kimray Catalog or the packing slip which is enclosed with each regulator.

Key Description

- 1 Nut-2" valve, plated steel
- 2 Diaphragm, nylon reinforced nitrile
- 3 Screw, plated steel
- 4 Stem Guide, plated steel
- 5 Housing, cast iron, ductile iron, or steel
- 6 Stem, stainless steel
- 7 O-Ring, nitrile
- 8 Screw, plated steel
- 9 Back Up, TFE
- 10 Cylinder, stainless steel
- 11 O-Ring, nitrile

Key Description

- 12 O-Ring, nitrile
- 13 Piston Seal Retainer, stainless steel
- 14 Ratio Plug, ductile iron
- 15 Seat, *nitrile or **polyurethane
- 16 Seat Disc, ductile iron
- 17 Lock Nut, plated steel
- 18 Breather Plug, aluminum
- 19 Spring
- 20 Bonnet, cast iron, ductile iron, or steel
- 21 Upper Plate, ductile iron
- 22 Lower Plate, ductile iron
- 23 Nut, plated steel

Key Description

- 24 O-Ring, nitrile
- 25 Back Up, TFE
- 26 Piston, stainless steel
- 27 O-Ring, nitrile
- 28 O-Ring, nitrile
- 29 Cage, ductile iron
- Removable Seat, **stainless steel
- 30 Stem, stainless steel
- 31 Gasket
- 32 Body, cast iron, ductile iron, or steel

*Cast Iron Valves

**Ductile Iron & Steel Valves