



PRESSURE REGULATOR

GAS PRESSURE DIFFERENTIAL

APPLICATION:

For maintaining a constant pressure drop across meter systems.

PRESSURE RANGE:

- Cast Iron: 5 psig to 125 psig
- Ductile Iron: 10 psig to 300 psig
- Steel: 10 psig to 300 psig

CAPACITY:

Refer to Table of Contents.

- Pilot Assembly
- Motor Valve Stem Assembly
- Downstream Pressure
- Upstream Pressure
- Motor Valve Diaphragm Pressure

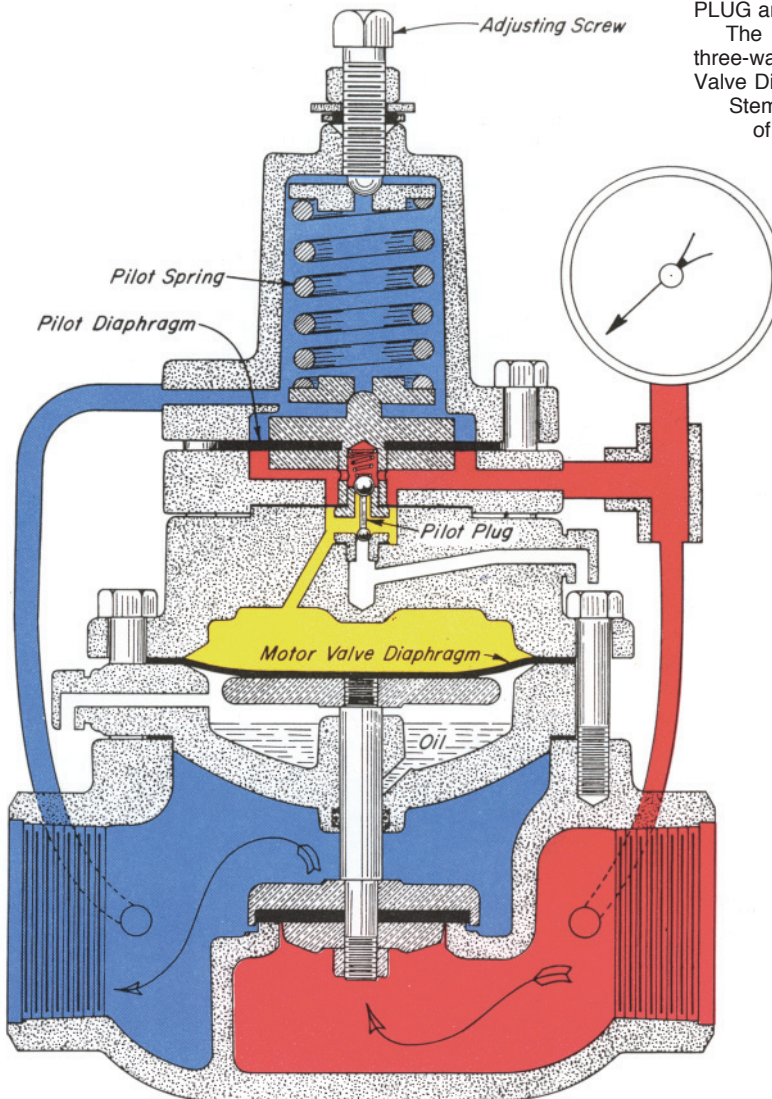

OPERATION:

This regulator is designed to control a set difference between Upstream Pressure (Red) and Downstream Pressure (blue). The differential pressure is set by changing the PILOT SPRING load with the ADJUSTING SCREW.

Any change in Downstream Pressure (Blue) will position the Motor Valve Stem Assembly until a like change in Upstream Pressure (Red) has occurred to maintain the set differential pressure.

Assume the load produced by the PILOT SPRING and Downstream Pressure (Blue) acting on the Pilot Assembly has caused it to move downward. This opens the upper seat of the PILOT PLUG (Red to Yellow) and closes the lower seat (Yellow to Atmosphere) admitting full Upstream Pressure (Red) to the MOTOR VALVE DIAPHRAGM, closing the motor valve seat. The area of the MOTOR VALVE DIAPHRAGM is twice the area of the motor valve seat, assuring tight shut-off.

As the Upstream Pressure (Red) increases to the set differential pressure, the Pilot Assembly moves upward to first close the upper seat (Red to Yellow) and open the pressure vent (Yellow to Atmosphere). The resulting decrease in Motor Valve Diaphragm Pressure (Yellow) permits the increased Upstream Pressure (Red), acting under the motor valve seat, to open the valve. With the motor valve open, the Upstream Pressure (Red) will decrease until the differential pressure across the PILOT DIAPHRAGM reaches the set point at which time the Pilot Assembly assumes a position in which both seats of the PILOT PLUG are closed.

The rapid but stable repositioning, intermittent bleed pilot, three-way valve action of the PILOT PLUG adjust the Motor Valve Diaphragm Pressure (Yellow) to position the Motor Valve Stem Assembly and provide true throttling action for any rate of flow.



PRESSURE REGULATOR

GAS PRESSURE DIFFERENTIAL STEEL

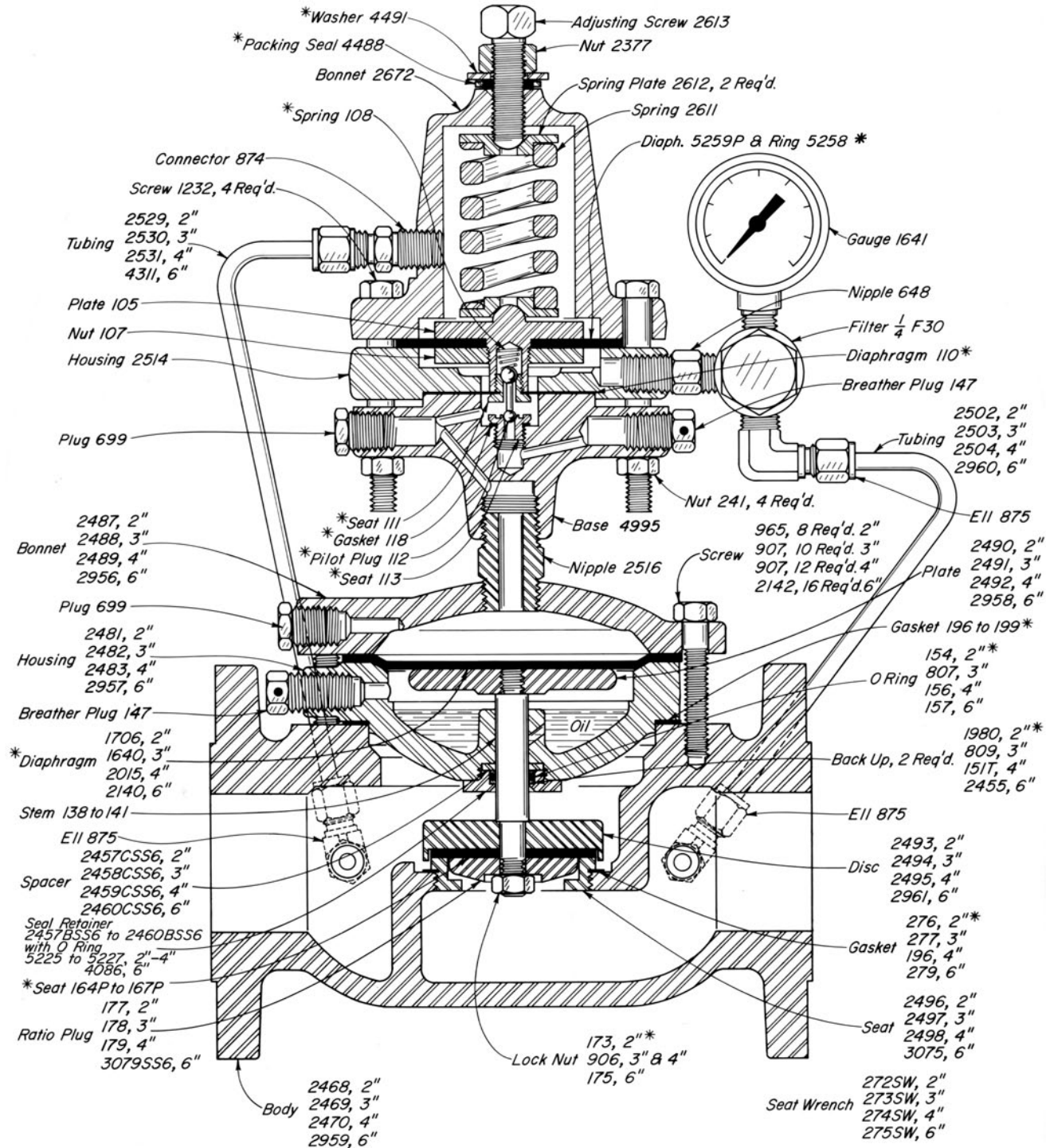

THRU VALVES AVAILABLE:

CAT. NO.	SIZE TYPE	REG. NO	OPER. PRES.	MAX W.P.	KIT
AGL	2" FLGD.	227 FGT PD-S	285	285	RBV
AGM	3" FLGD.	327 FGT PD-S	285	285	RBZ
AGN	4" FLGD.	427 FGT PD-S	285	285	RCA
AGO	6" FLGD.	627 FGT PD-S	285	285	RBW

NOTES:

Dimensions, refer to Table of Contents.

*These parts are recommended spare parts and are stocked as repair kits.

The numbers of a series assigned to a part indicate different line sizes. For example: Seat 164P-2", 165P-3", 166P-4", 167P-6".



GAS CAPACITY CHARTS

200, 285, 300 & 500 psig Maximum W.P. Valves

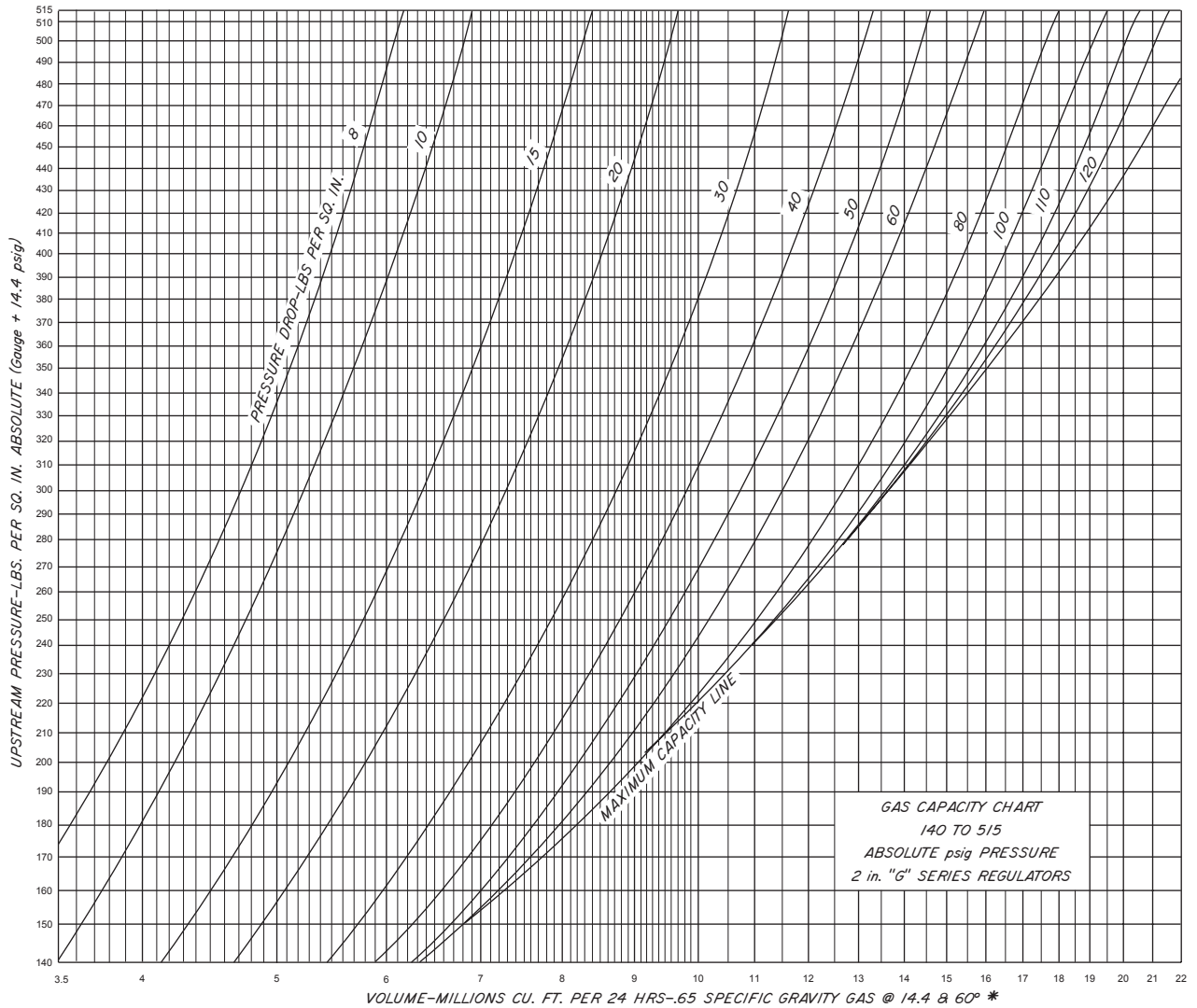

Gas capacities are based on pressure taken immediately upstream and downstream from the regulator in a wide open position.

Critical flow exists across a valve or orifice when the downstream absolute pressure is approximately half of the upstream absolute pressure. Any decrease in downstream pressure will not increase the flow through the valve. Critical flow conditions on the charts are represented by the MAXIMUM CAPACITY LINE.

HOW TO USE CHARTS: Locate UPSTREAM PRESSURE at left of chart. Follow horizontally across to PRESSURE DROP (upstream minus downstream pressure). Read VOLUME directly below. If the horizontal projection of the upstream pressure does not intersect the given pressure drop, flow is critical. In this case project UPSTREAM PRESSURE horizontally to the MAXIMUM CAPACITY LINE and read VOLUME directly below.

*For gravity correction multiply above capacities by $\sqrt{\frac{.65}{G}}$ where G equals specific gravity of gas.

GAS CAPACITY CHARTS

220, 285, & 300 psig Maximum W.P. Valves

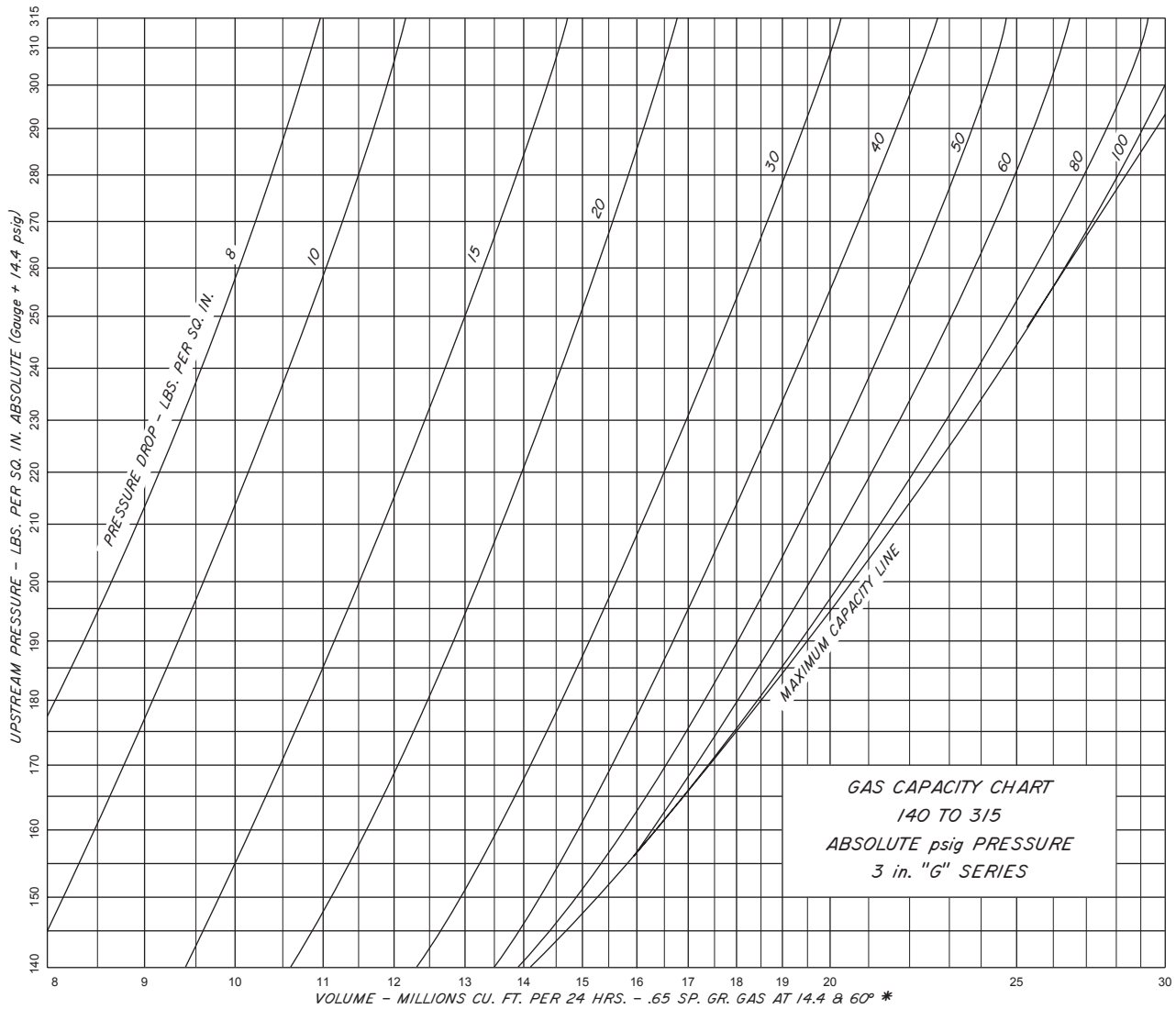

Gas capacities are based on pressure taken immediately upstream and downstream from the regulator in a wide open position.

Critical flow exists across a valve or orifice when the downstream absolute pressure is approximately half of the upstream absolute pressure. Any decrease in downstream pressure will not increase the flow through the valve. Critical flow conditions on the charts are represented by the MAXIMUM CAPACITY LINE.

HOW TO USE CHARTS: Locate UPSTREAM PRESSURE at left of chart. Follow horizontally across to PRESSURE DROP (upstream minus downstream pressure). Read VOLUME directly below. If the horizontal projection of the upstream pressure does not intersect the given pressure drop, flow is critical. In this case project UPSTREAM PRESSURE horizontally to the MAXIMUM CAPACITY LINE and read VOLUME directly below.

*For gravity correction multiply above capacities by $\sqrt{\frac{.65}{G}}$ where G equals specific gravity of gas.

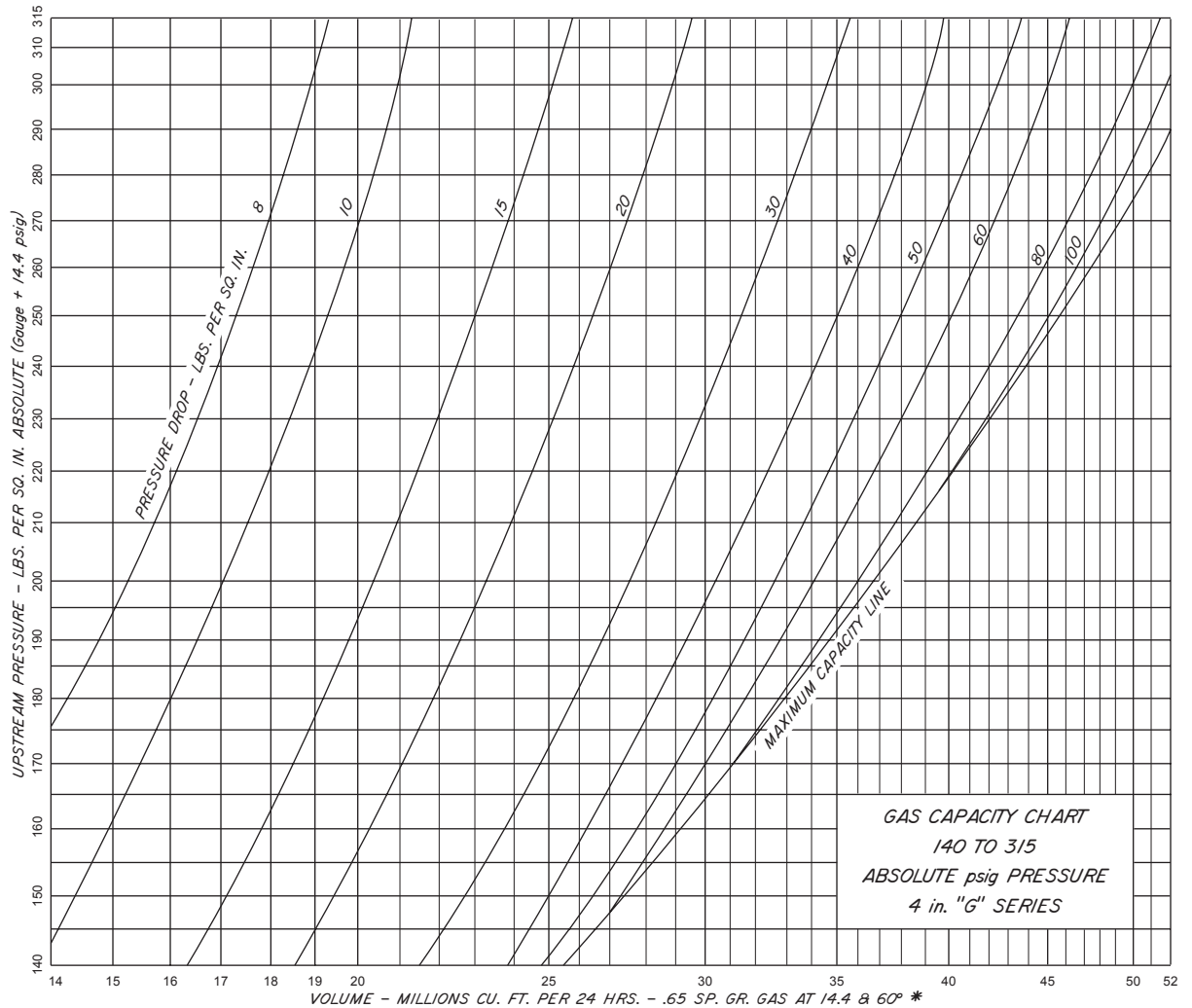

Gas capacities are based on pressure taken immediately upstream and downstream from the regulator in a wide open position.

Critical flow exists across a valve or orifice when the downstream absolute pressure is approximately half of the upstream absolute pressure. Any decrease in downstream pressure will not increase the flow through the valve. Critical flow conditions on the charts are represented by the MAXIMUM CAPACITY LINE.

HOW TO USE CHARTS: Locate UPSTREAM PRESSURE as left of chart. Follow horizontally across to PRESSURE DROP (upstream minus downstream pressure). Read VOLUME directly below. If the horizontal projection of the upstream pressure does not intersect the given pressure drop, flow is critical. In this case project UPSTREAM PRESSURE horizontally to the MAXIMUM CAPACITY LINE and read VOLUME directly below.

*For gravity correction multiply above capacities by $\sqrt{\frac{.65}{G}}$ where G equals specific gravity of gas.

GAS CAPACITY CHARTS

220, 285 & 300 psig Maximum W.P. Valves

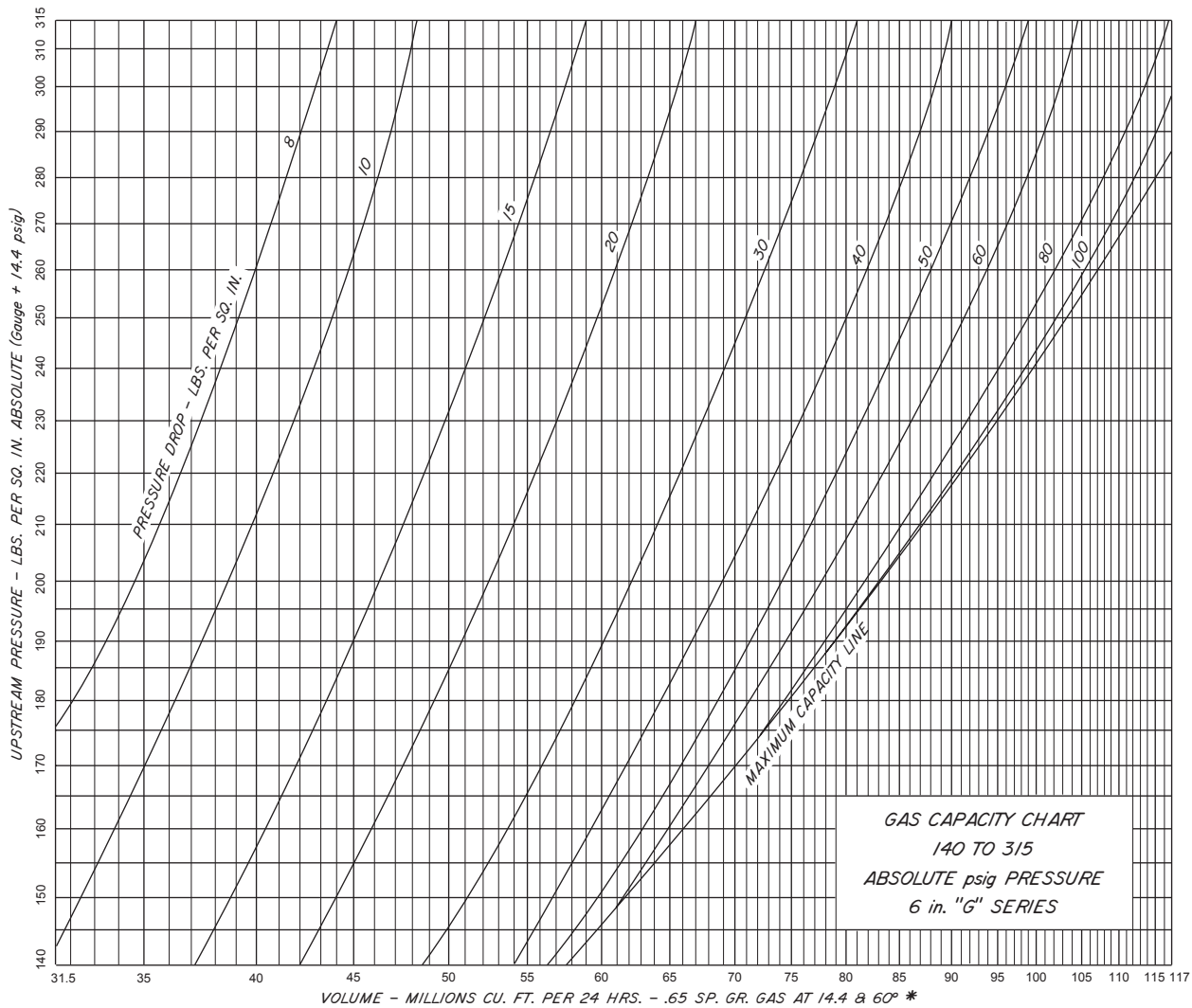

Gas capacities are based on pressure taken immediately upstream and downstream from the regulator in a wide open position.

Critical flow exists across a valve or orifice when the downstream absolute pressure is approximately half of the upstream absolute pressure. Any decrease in downstream pressure will not increase the flow through the valve. Critical flow conditions on the charts are represented by the MAXIMUM CAPACITY LINE.

HOW TO USE CHARTS: Locate UPSTREAM PRESSURE at left of chart. Follow horizontally across to PRESSURE DROP (upstream minus downstream pressure). Read VOLUME directly below. If the horizontal projection of the upstream pressure does not intersect the given pressure drop, flow is critical. In this case project UPSTREAM PRESSURE horizontally to the MAXIMUM CAPACITY LINE and read VOLUME directly below.

*For gravity correction multiply above capacities by $\sqrt{\frac{.65}{G}}$, where G equals specific gravity of gas.



LIQUID CAPACITY CHARTS

300 psig Maximum W.P. Valves

CAPACITY-Bbls. Water/Day, Steady Flow

PRESSURE DROP ACROSS VALVE PSIG	VALVE SIZE - INCHES			
	1	2	3	4
1	745	1,760	3,350	7,800
2	1,060	2,500	4,900	11,000
3	1,300	3,050	6,100	13,500
4	1,500	3,500	7,000	15,600
5	1,700	3,900	7,800	17,500
10	2,300	5,600	11,000	24,700
15	2,900	6,800	13,500	30,200
20	3,300	7,900	15,600	34,900
30	4,100	9,600	19,200	42,700
40	4,700	11,100	22,100	49,300
50	5,300	12,400	24,800	55,200
60	5,800	13,600	27,100	60,500
70	6,200	14,700	29,300	65,400
80	6,700	15,700	31,300	69,800
100	7,500	17,600	33,500	78,200
125	8,400	19,700	39,200	87,500
150	9,300	21,500	40,750	93,000
200	10,750	25,000	47,000	108,000
250	12,100	28,000	52,000	120,000
300	13,300	30,900	57,250	130,000

For gravity correction, multiply the above figures by $\sqrt{\frac{1}{G}}$
 Where "G" is the specific gravity of the flowing liquid.

GAS SERIES REGULATOR



DIMENSIONS

FOR: BACK PRESSURE
UPSTREAM DIFFERENTIAL PRESSURE
PRESSURE REDUCING-BALANCED
PRESSURE REDUCING VACUUM

PRESSURE DIFFERENTIAL
PRESSURE REDUCING
BACK PRESSURE VACUUM
LIQUID BACK PRESSURE

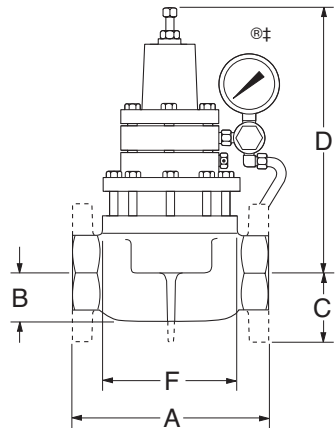

CAST IRON OR DUCTILE

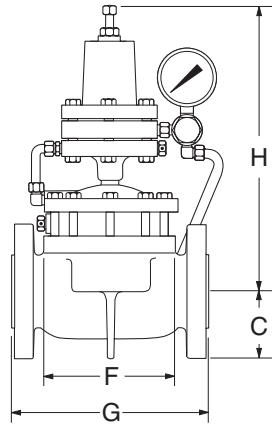

STEEL

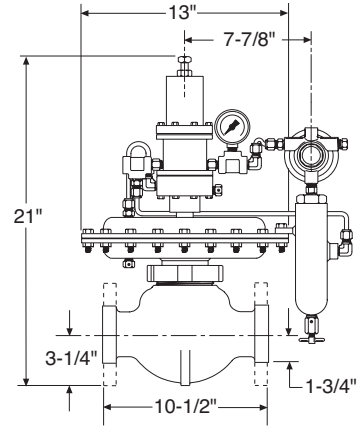

250 S/FGT-BP-S

FOR: LOW PRESSURE BACK PRESSURE
OUNCES BACK PRESSURE TO VACUUM
OUNCES PRESSURE REDUCING
OUNCES PRESSURE REDUCING VACUUM
VACUUM BACK PRESSURE TO VACUUM

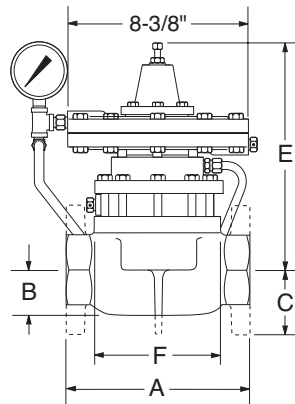

CAST IRON OR DUCTILE

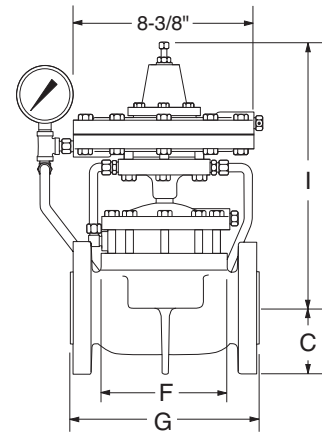

STEEL

LINE SIZE	BODY STYLE	A	B	C	D*	E	F	G	H*	I
1 "	SCRD	4 3/8"	1 1/8"		7 1/2"	11 5/8"	3 1/4"			
2 "	SCRD	8 1/2"	2 1/8"		11 1/2"	10 1/2"	6 1/2"			
	FLGD	9"		3	11 1/2"	10 1/2"	6 1/2"	9 1/8"	14 1/2"	14"
	GRVD	8 3/4"	2 1/8"		11 1/2"	10 1/2"	6 1/2"			
250 S/FGT	SCRD			1 3/4"				10 1/2"		
	FLGD			3 1/4"				10 1/2"		
3 "	SCRD	12"	3 1/16"		13"	12"	8 1/2"			
	FLGD	12 3/16"		3 3/4"	13"	12"	8 1/2"	12 5/16"	16 1/2"	15 1/2"
4 "	SCRD	15"	4"		14 1/2"	13 3/16"	10 1/2"			
	FLGD	15 1/8"		4 1/2"	14 1/2"	13 3/16"	10 1/2"	15"	18 1/2"	16 11/16"
6 "	FLGD	22 1/8"		5 1/2"	17"	14 7/8"	16"	22"	20 1/2"	18 3/8"

FLANGE DIMENSIONS ARE ANSI 125/150 STANDARD. *Add 7/8" to PRB and USDP Regulators for this dimension.